

Signals.SchDoc

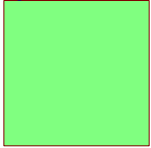

Audio.SchDoc



CF.SchDoc

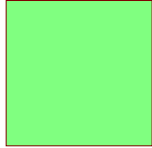

MISC.SchDoc

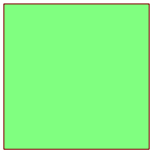

Power.SchDoc

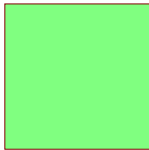

Ext.SchDoc

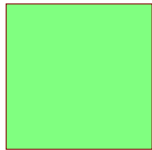

Mem.SchDoc

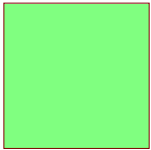

Display.SchDoc

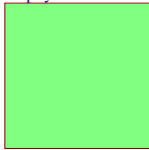

PM1

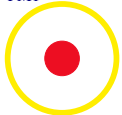

DOT\_POSITION\_MARKER

PM2

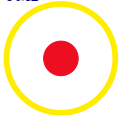

DOT\_POSITION\_MARKER

PM3



DOT\_POSITION\_MARKER

H1

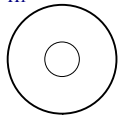

MHole3,2mm

H2

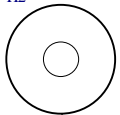

MHole3,2mm

H3

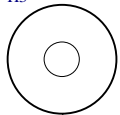

MHole3,2mm

H4

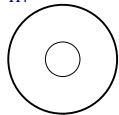

MHole3,2mm



Title: <b>Overview</b>		
A4	Nummer: <b>TE0141</b>	Rev. <b>01</b>
Datum: 20.10.2004	Zeichner: Trenz Electronic GmbH / TT	Blatt 1 von 9
Filename: <b>Main.SchDoc</b>		

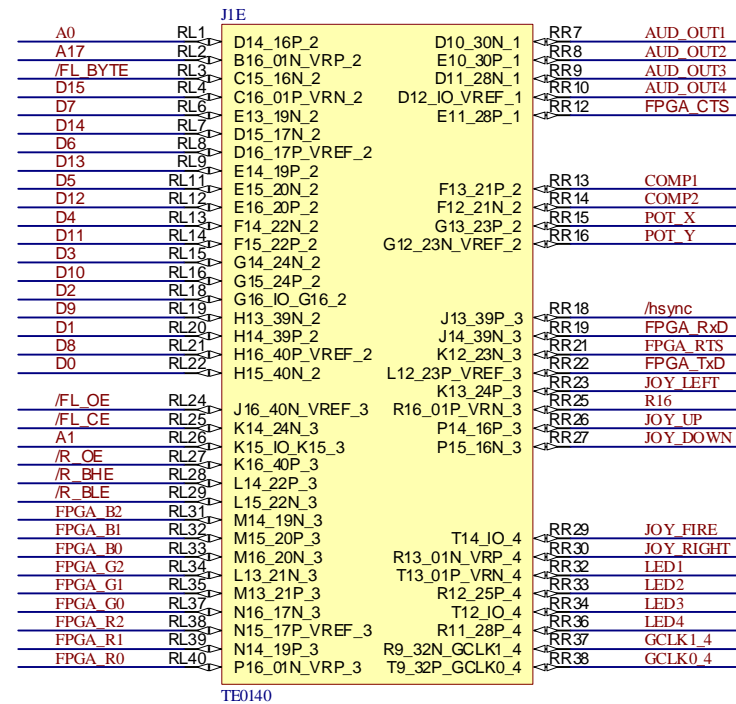
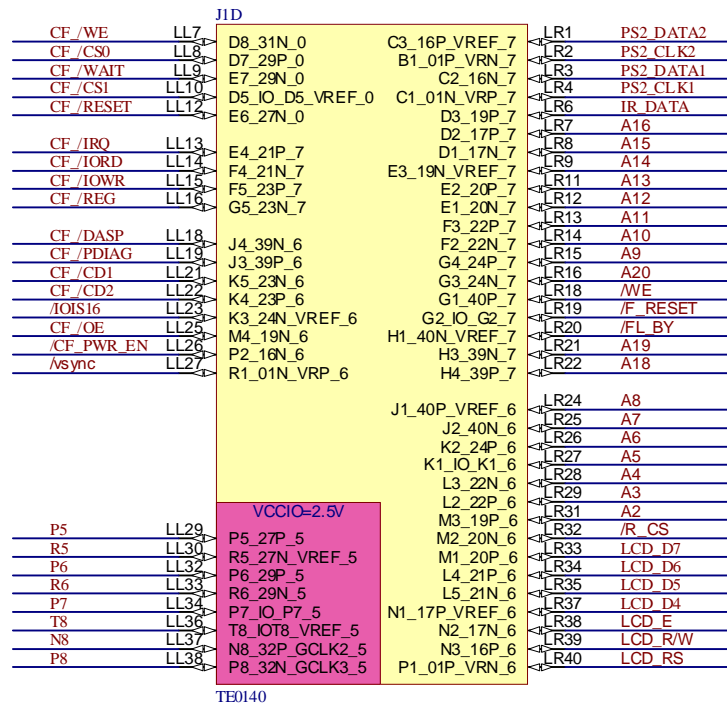

Title: Signals from FPGA Module			
A4	Nummer: TE0141	Rev. 01	
Datum: 20.10.2004	Zeichner: Trenz Electronic GmbH / TT	Blatt 2 von 9	
Filename: Signals.SchDoc			

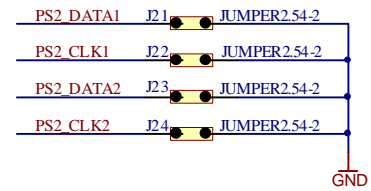
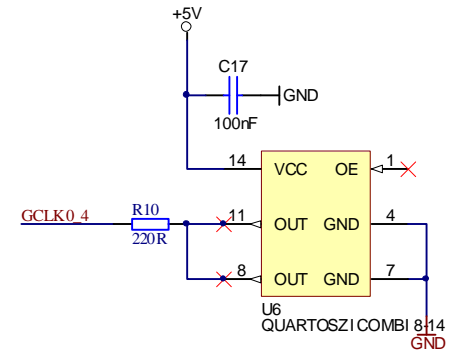
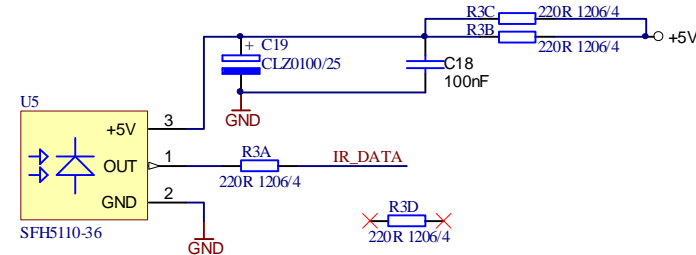
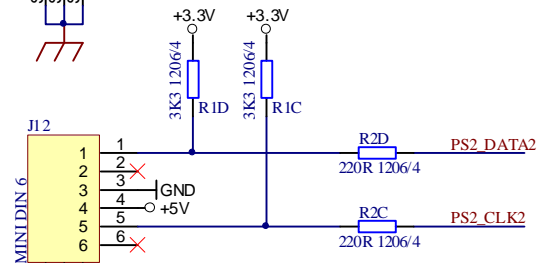
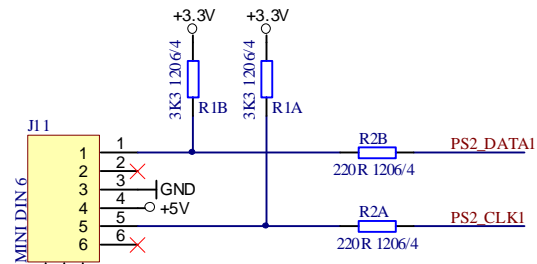
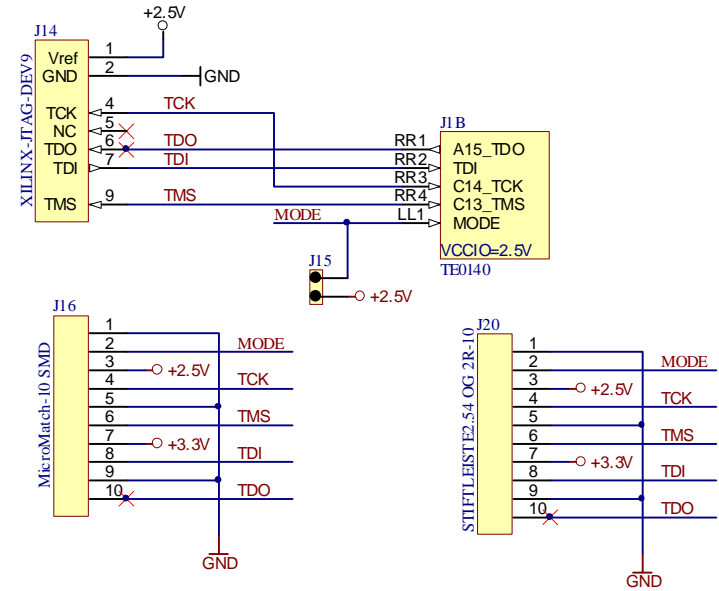
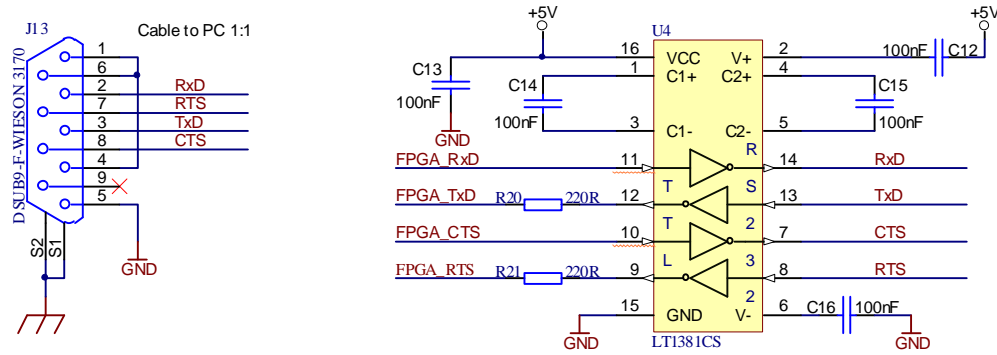

	Title: RS232, PS/2, IR, JTAG and User Oszillator	
	A4	Nummer: TE0141 Rev. 01
	Datum: 20.10.2004	Zeichner: Trenz Electronic GmbH / TT Blatt 3 von 9
	Filename: MISC.SchDoc	

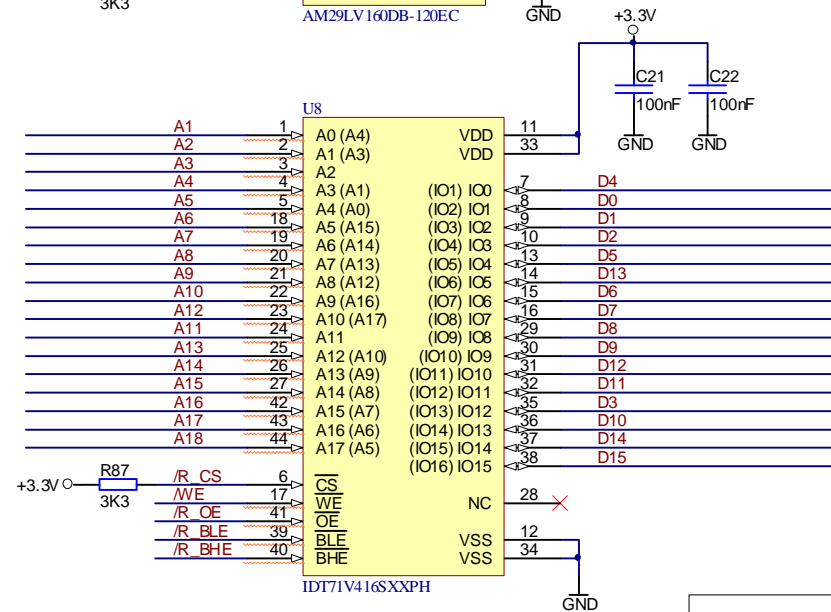
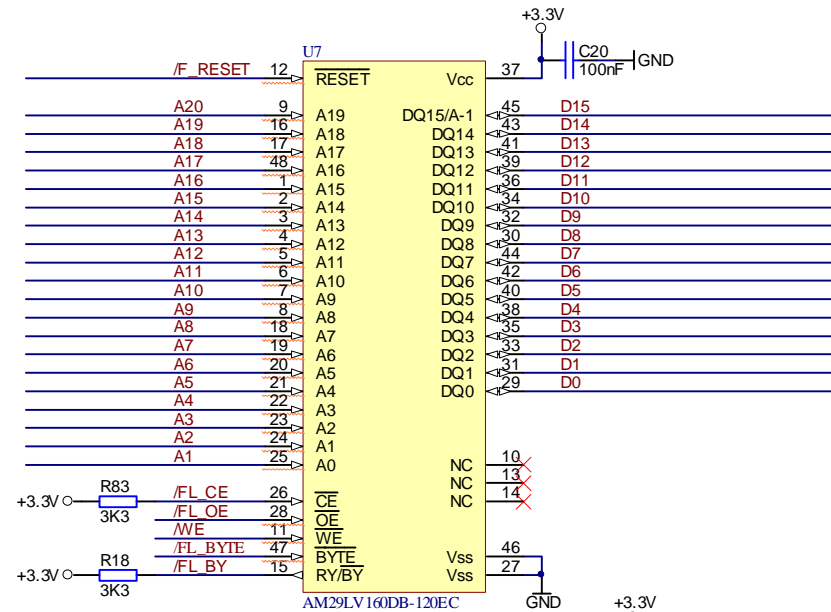

Title: <b>Memory Subsystem</b>			
A4	Nummer: <b>TE0141</b>	Rev. <b>01</b>	
Datum: <b>20.10.2004</b>	Zeichner: <b>Trenz Electronic GmbH / TT</b>	Blatt <b>4</b> von <b>9</b>	
Filename: <b>Mem.SchDoc</b>			

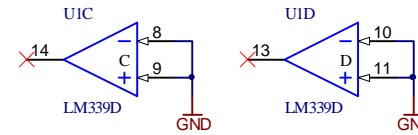
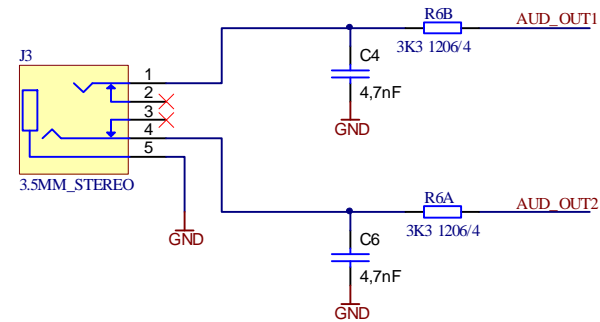
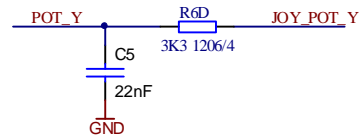
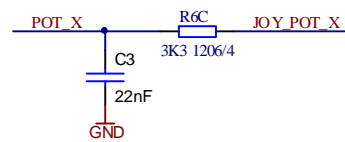
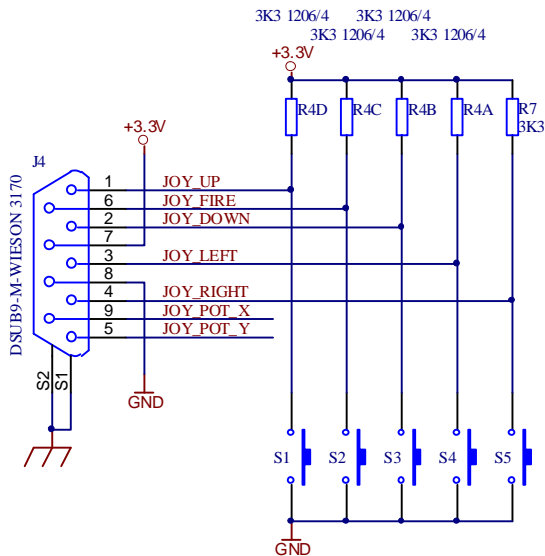
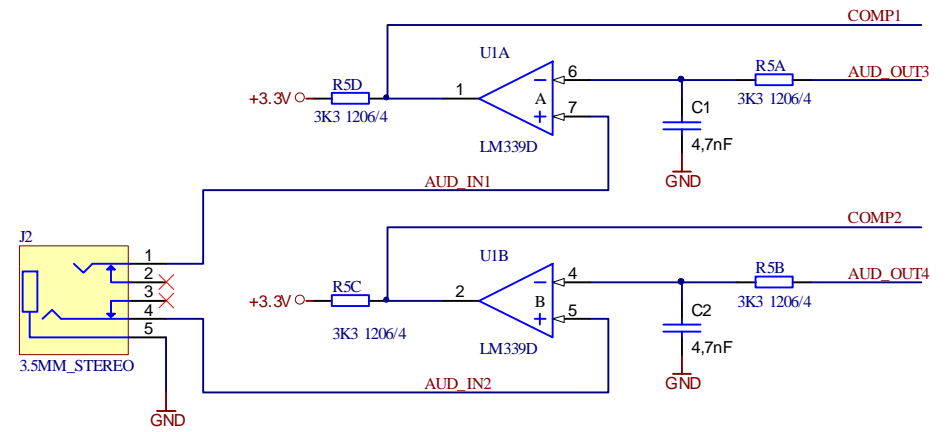
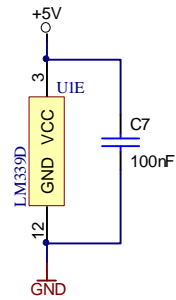
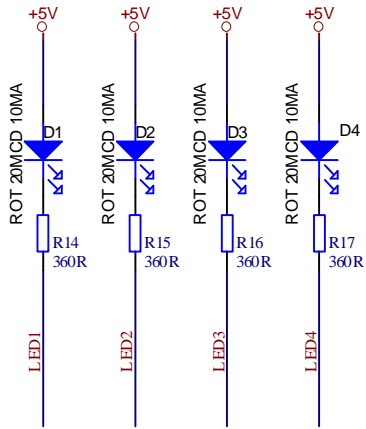

Title: Joystick, Audio and LED's		
A4	Nummer: TE0141	Rev. 01
Datum: 20.10.2004	Zeichner: Trenz Electronic GmbH / TT	Blatt 5 von 9
Filename: Audio.SchDoc		

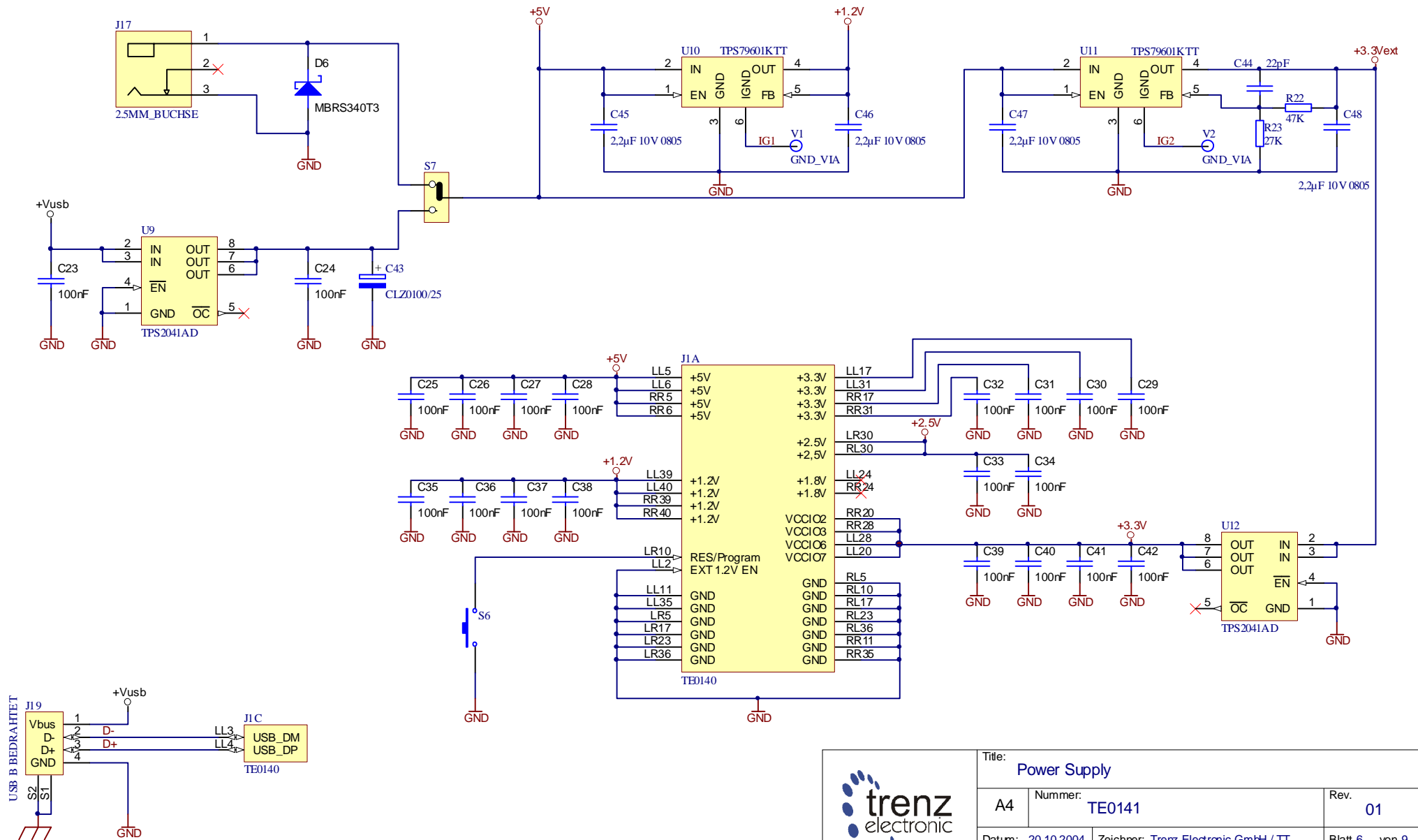

Title: Power Supply		
A4	Nummer: TE0141	Rev. 01
Datum: 20.10.2004	Zeichner: Trenz Electronic GmbH / TT	Blatt 6 von 9
Filename: Power.SchDoc		

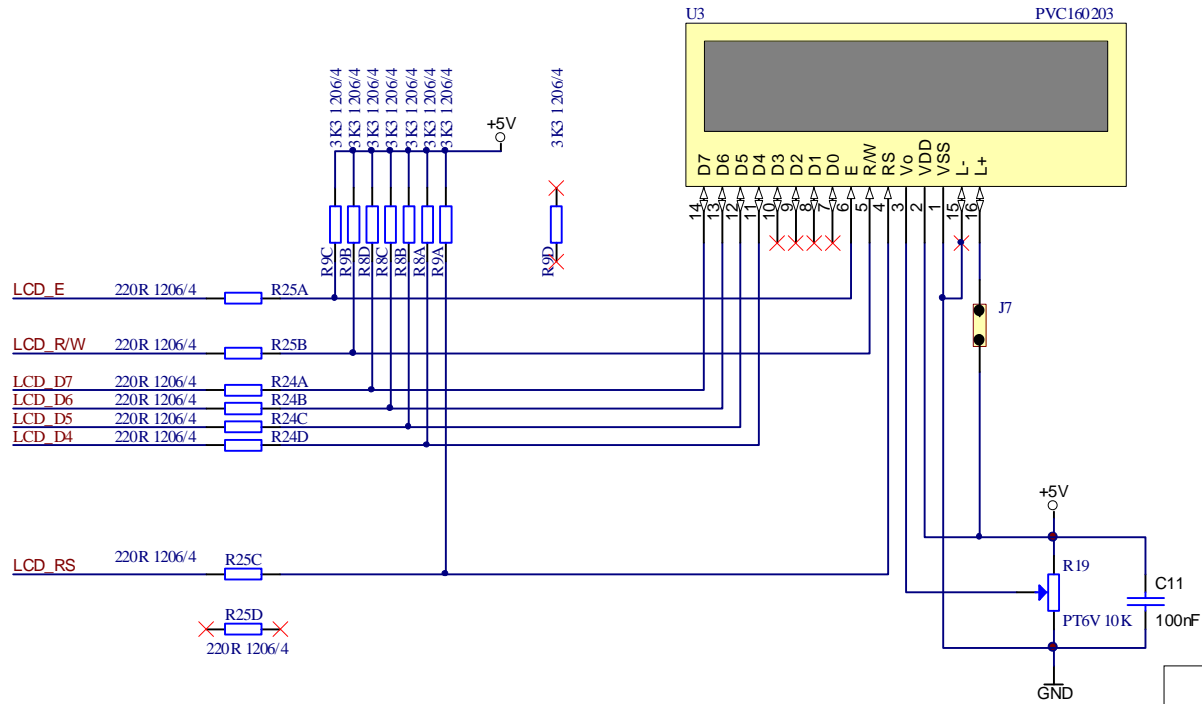
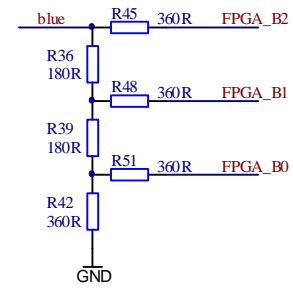
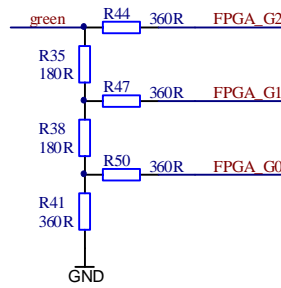
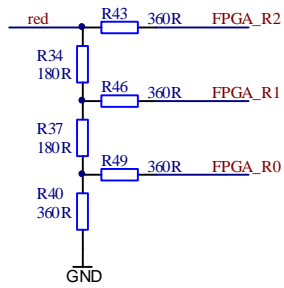
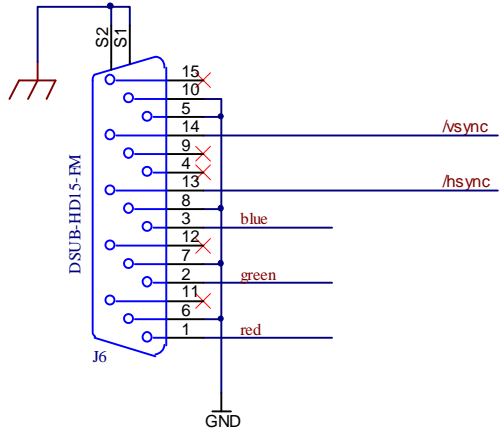

Title: VGA and LCD Display		
A4	Nummer: TE0141	Rev. 01
Datum: 20.10.2004	Zeichner: Trenz Electronic GmbH / TT	Blatt 7 von 9
Filename: Display.SchDoc		

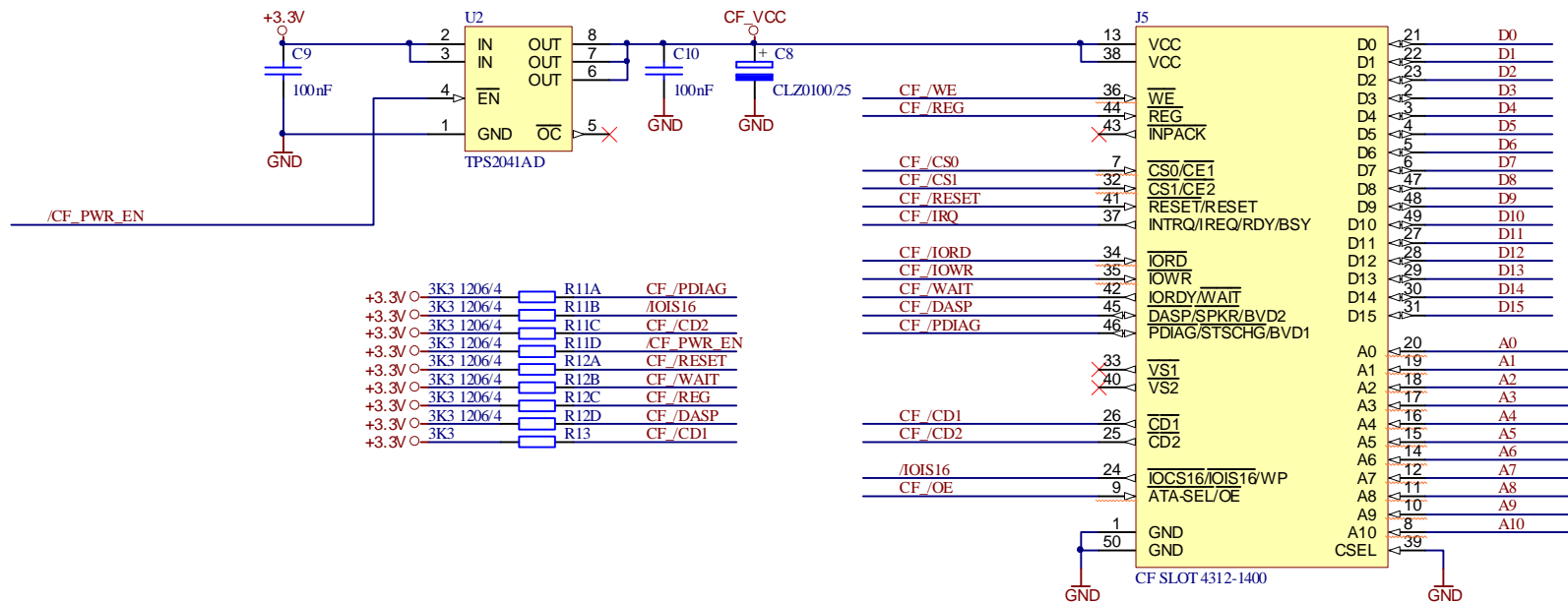

Title: Compact Flash Slot		
A4	Nummer: TE0141	Rev. 01
Datum: 20.10.2004	Zeichner: Trenz Electronic GmbH / TT	Blatt 8 von 9
Filename: CF.SchDoc		



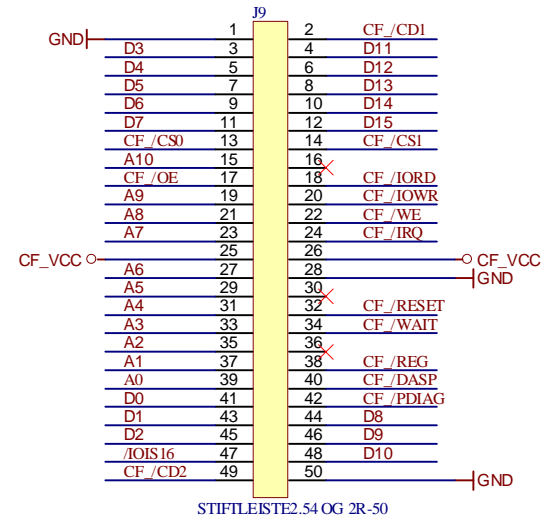
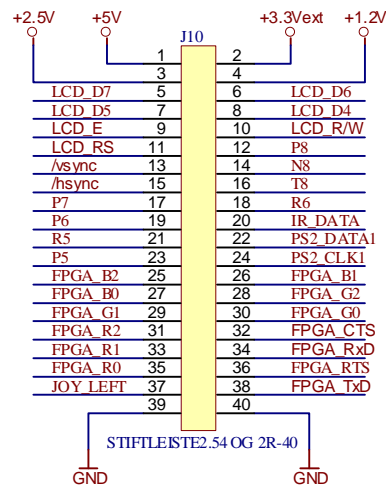
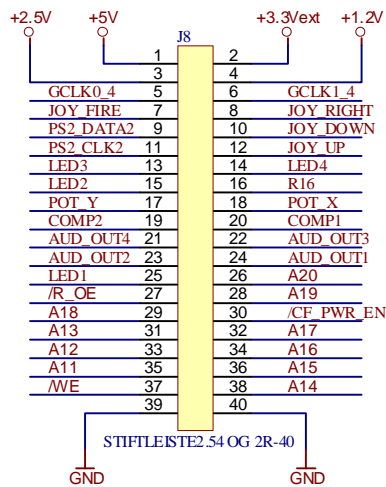

Title: External Connectors		
A4	Nummer: TE0141	Rev. 01
Datum: 20.10.2004	Zeichner: Trenz Electronic GmbH / TT	Blatt 9 von 9
Filename: Ext.SchDoc		