

8 7 6 5 4 3 2 1

F

F

E

E

D

D

C

C

B

B

A

A

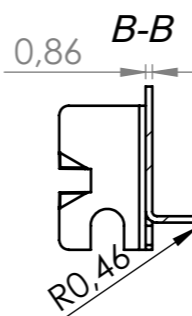
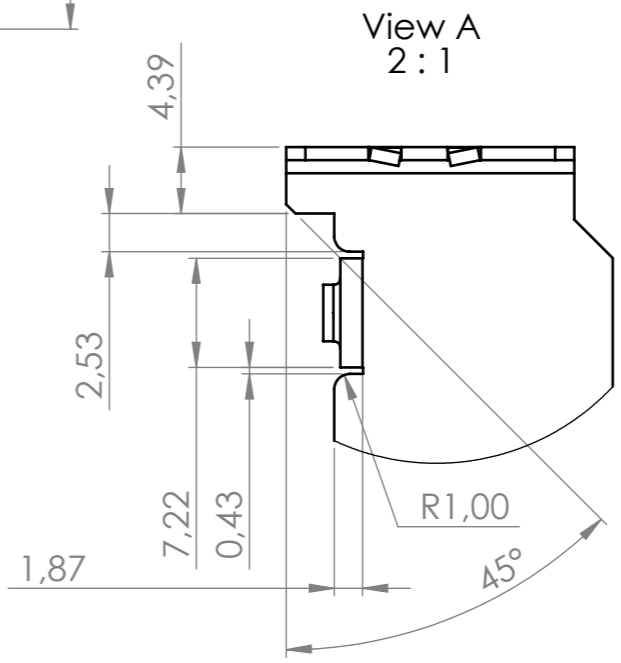
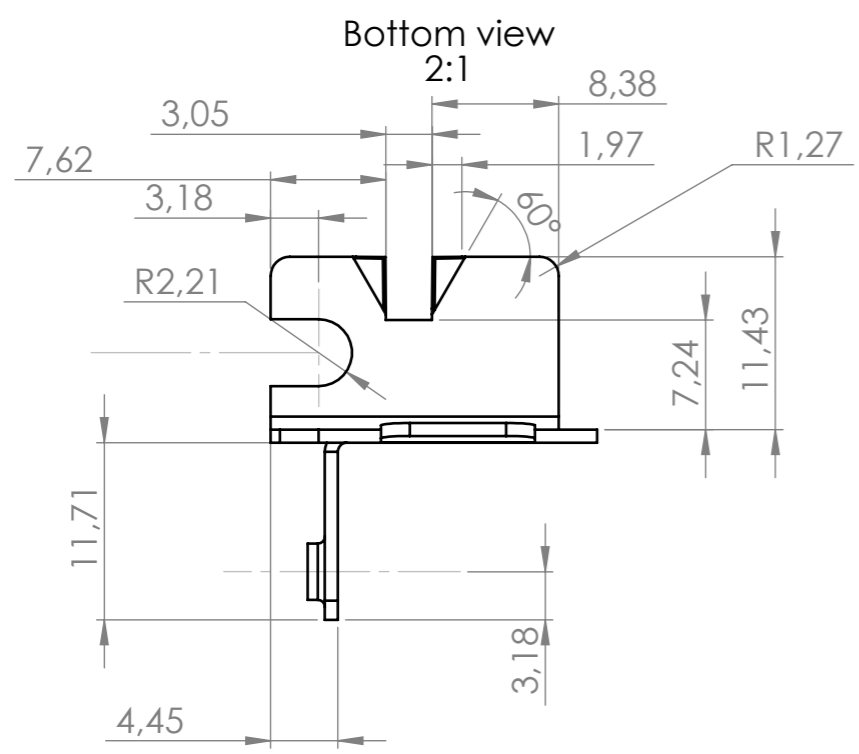
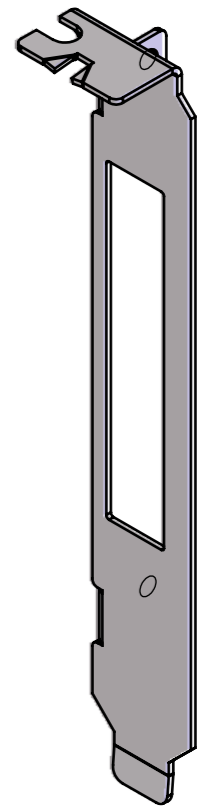
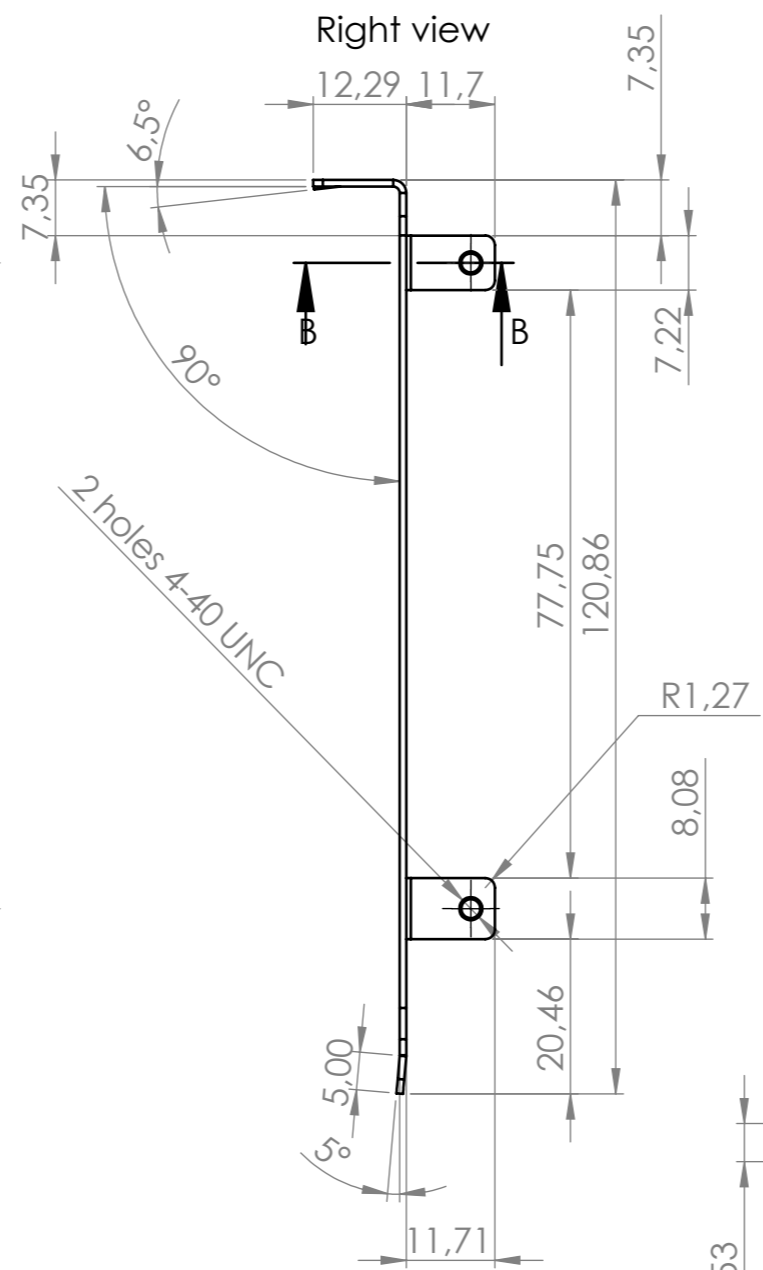
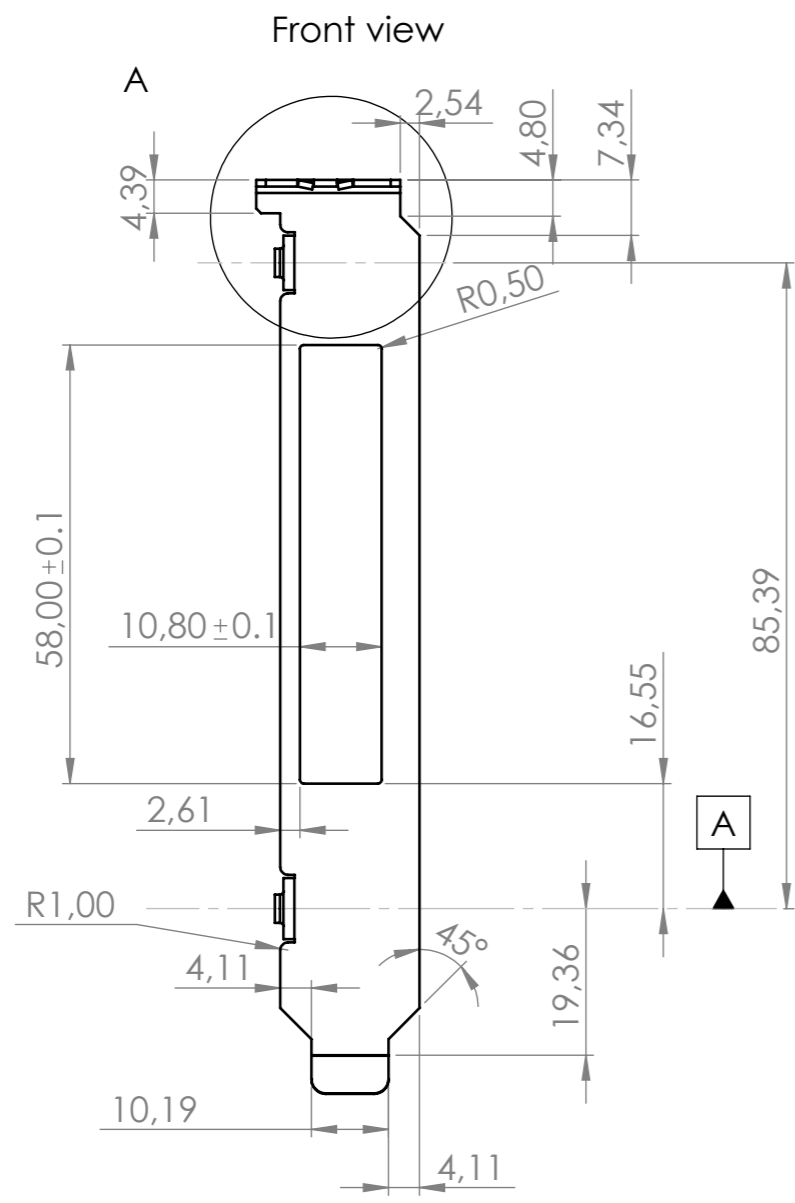

UNLESS OTHERWISE SPECIFIED: DIMENSIONS ARE IN MILLIMETERS SURFACE FINISH: TOLERANCES: LINEAR: ANGULAR:			FINISH:	DEBURR AND BREAK SHARP EDGES	DO NOT SCALE DRAWING	REVISION	01
					Beendorf Str. 23, 32609 Hüllhorst, GERMANY www.trenz-electronic.de		
					TITLE: <b>Front Panel</b>		
					DWG NO.		<b>34034</b>
					SCALE:1:1		SHEET 1 OF 1
DRAWN			Grishchenko	SIGNATURE	DATE	MATERIAL: 0.34 THK (20GA) C1010/1020 CRS ZINK PLATE	
CHK'D			Brose		23.20.24	WEIGHT: 12.675	
APPV'D			Brose		23.20.24	A3	
MFG							
Q.A			Schlemmer		23.20.24		

8 7 6 5 4 3 2 1