

Regarding the usage of our schematics and alike documentation for Trenz baseboard TE0703.

Baseboard is Open Source Hardware and therefore free to use, adapt and can be modified to suit your needs as described in the "The MIT License".

Permission is hereby granted, free of charge, to any person obtaining a copy of this hardware and associated documentation files (the "Product"), to deal in the Product without restriction, including without limitation the rights to use, copy, modify, merge, publish, distribute, sublicense, and/or sell copies of the Product, and to permit persons to whom the Product is furnished to do so.

Schematics and other handouts serve for informational purposes only!

Drawn by	ED
Checked by	MT
Assembly variant	Default
Created by	ED
Modified by	ED
Modified at	2023-09-07



Title: TE0703 – Legal Notices		
A4	Number: TE0703 Default	Rev. 07
Date: 14.03.2024	Copyright: Trenz Electronic GmbH	Page 1 of 14
Filename: Legal Notices Baseboards.SchDoc		

REV	DATE	Description	
-05	2017-11-23	<ol style="list-style-type: none"> <li>[J5] changed to 3 pin jumper to select 3.3V or 1.8V, added 3pin jumpers for each bank</li> <li>PWR connector type changed THT-&gt;SMD</li> <li>changed FT2232 different IC package (56pins)</li> <li>changed micro SD-card slot</li> <li>changed micro-USB</li> <li>added series resistors 10K to FLED0, FLED1 and connect to CPLD</li> <li>added serial number (traceability pad)</li> </ol>	
-06	2019-08-29 2022-05-04	<ol style="list-style-type: none"> <li>microSD card connector ([J3]) changed to industrial</li> <li>changed PB ([S1]) to industrial</li> <li>replaced input power protection</li> <li>added jumper ([J11]) to select SD level shifter voltage on FPGA side</li> <li>added power switch for SD level shifter supply voltages to ensure power sequencing of level shifter</li> <li>replaced [R5] and VBUS capacitors, add 00hm resistors to OTG-ID</li> <li>replaced jumpers by SMD versions, moved VBAT to other position</li> <li>routing length of diff pairs B34_L17, B34_L15, B34_L21, B34_L13, B34_L10, B34_L20 changed</li> <li>Replaced [R31] by 953K and [R25] by 147K</li> <li>Set S/N Track-it pad not fitted</li> </ol>	
-07	2023-09	<ol style="list-style-type: none"> <li>Changed DCDC EN6347QI ([U3]) to MPM3860GQW-Z.</li> <li>Changed load switch TPS27081ADDCR ([Q1]) to MP5077GG-Z.</li> <li>Changed clock SiT8008AI-73-XXS-12.000000E ([U6]) to SiT8008BI-73-XXS-12.000000E.</li> <li>Changed SD Card connector ([J3]) from 504077-1891 to MEM2052-00-195-00-A.</li> <li>Changed USB connector ([J12]) from 629105150521 to 629105150921.</li> <li>Changed pin header ([J7]) from two pins to three pins and added jumper [J20].</li> <li>Added testpoints [TP1]... [TP30].</li> <li>Changed voltage rating for 1 uF capacitors ([C38], [C39]) from 6.3 V to 16 V.</li> <li>Changed voltage rating for 47 uF capacitor ([C48]) from 6.3 V to 10 V and size from 1206 to 0805.</li> <li>Changed tolerance for 22 uF capacitor ([C22]) from 10 % to 20 % and size from 1206 to 0805.</li> <li>Changed resistor values for 10 kOhm resistors ([R10], [R14], [R24], [R27], [R37], [R38]) to 12 kOhm.</li> <li>Changed resistor values from 4.7 kOhm to 5.1 kOhm for resistors [R17]... [R20].</li> <li>Changed fiducials.</li> <li>Named [Q1] enable signal to "EN_3.3V_SD".</li> <li>Added decoupling capacitors: <ol style="list-style-type: none"> <li>[C55], [C57]... [C61] for U5.</li> <li>[C62]... [C64] for [J3].</li> <li>[C65] for [U1].</li> </ol> </li> <li>Added pull-up resistor [R43] for "USB_OC".</li> <li>Removed VG96 from BOM.</li> <li>Removed S/N Track-it pad.</li> <li>Added UKCA logo.</li> <li>Changed address on silkscreen.</li> <li>Updated components from library.</li> <li>Updated revision history.</li> <li>Updated documentation.</li> <li>Updated power overview.</li> </ol>	ED

	Title: TE0703 – Revision History		
	A4	Number: TE0703 Default	Rev. 07
	Date: 14.03.2024	Copyright: Trenz Electronic GmbH	Page 2 of 14
	Filename: Revision_Changes.SchDoc		

# Supported Voltage Ranges:

Power Rail	Direction*	Range	Tolerance	Description	Note
5VIN	IN/OUT	5.0 V	+/- 5 %	Baseboard Power	Baseboard Power Supply.
VCCIOA	IN/OUT	-	-	Micromodule Power	Dependent on baseboard/module combination, on baseboard settings and VG96 requirements.
VCCIOB	IN/OUT	-	-	Micromodule Power	Dependent on baseboard/module combination, on baseboard settings and VG96 requirements.
VCCIOC	IN/OUT	1.2 V - 3.3V	-	Micromodule Power	Range based on baseboard. Dependent on baseboard/module combination, on baseboard settings and VG96 requirements.
VCCIOD	IN/OUT	-	-	Micromodule Power	Dependent on baseboard/module combination, on baseboard settings and VG96 requirements.
VCCJTAG	IN	1.2 V - 3.3V	-	JTAG Reference	JTAG Reference Voltage from module. Consult module documentation.
M1.8VOUT	IN	1.8 V	+/- 3 %	Baseboard Power	Range based on baseboard. Consult module requirements.
M3.3VOUT	IN	3.3 V	+/- 3 %	Baseboard Power	Range based on baseboard. Consult module and VG96 requirements.
ETH-VCC	IN	-	-	RJ45 Power	Consult module requirements.
3.3V	OUT	3.3 V	+/- 3 %	Power for System	Range based on baseboard. Consult module and VG96 requirements.
VBAT	OUT	-	-	Power for Module.	Consult module requirements.

\* IN/OUT dependent on usage mode.

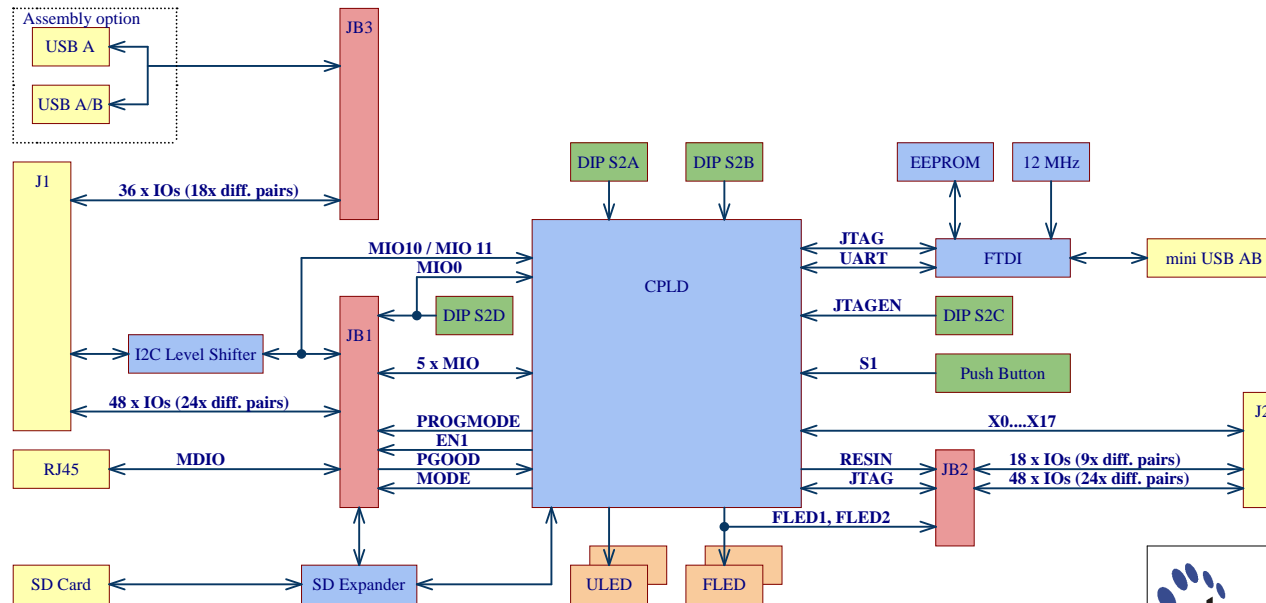

## I2C Address:

Device	I2C ADDR	Note
CPLD	USB	Firmware dependent.
VG96	J1A	Depends on connection.

## Legend:

- B2B Connector
- Connector
- LED Interface
- Switchable Interface
- On-board Components



Title: TE0703 – System Overview		
A4	Number: TE0703 Default	Rev. 07
Date: 14.03.2024	Copyright: Trenz Electronic GmbH	Page 3 of 14
Filename: TE0703-Overview.SchDoc		

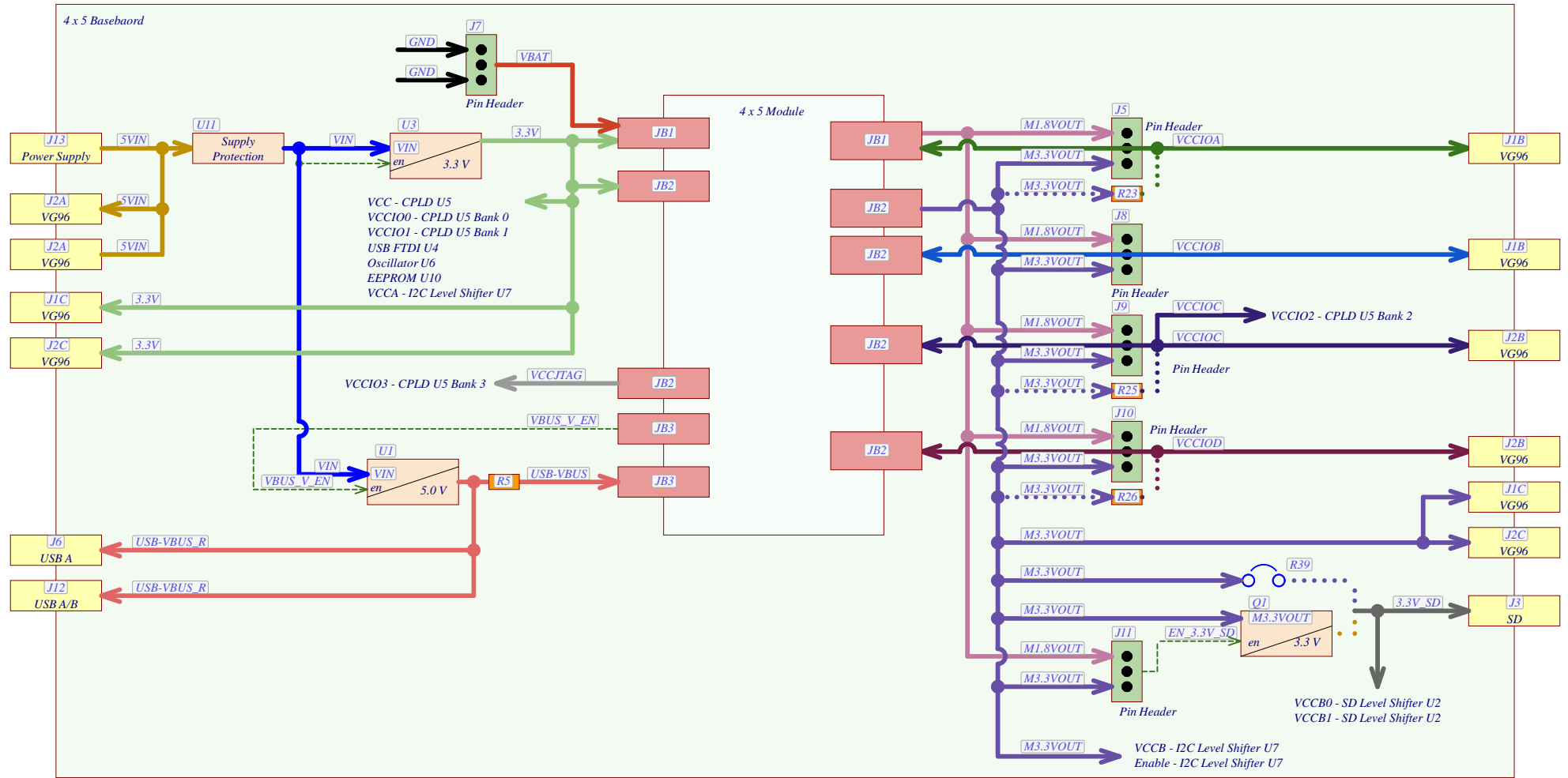

### Legend:

- 5VIN Net name
- Power bus
- Control signal
- B2B Connector
- Connector
- Pin Header
- Assembly Option
- On-Board Power Supply Device



Title: TE0703 – Power Overview			
A4	Number: TE0703 Default	Rev. 07	
Date: 14.03.2024	Copyright: Trenz Electronic GmbH	Page 4 of 14	
Filename: Power_Overview.SchDoc			

Special notes:

.

.

FIDU-DOT - small FIDU-DOT - small FIDU-DOT - small



PM1 FIDU-DOT - small PM2 FIDU-DOT - small PM3 FIDU-DOT - small

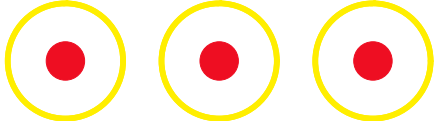

PM4 PM5 PM6

Serial  
Serial  
Serialnumber 6,3 x 6.3mm  
MISC1  
Digilent Serialnumber  
Digilent\_SN

Mount.Hole 3.2mm Mount.Hole 3.2mm Mount.Hole 3.2mm Mount.Hole 3.2mm

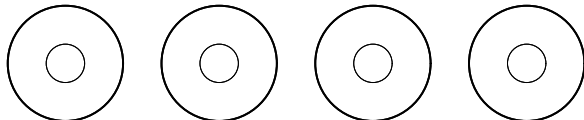

GND GND GND GND

UKCA1

UKCA Logo on Top Overlay

UKCA-TOPOVERLAY

CE1

CE Logo on Top Overlay

CE-TOPOVERLAY

MECH10

TE Address Overlay

LOGO ADDRESS

LOGO1

TE Logo PRINT Layer

LOGO PRINT

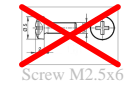

Screw M2.5x6

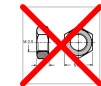

Nut M2.5 DIN934

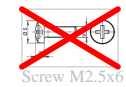

Screw M2.5x6

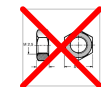

Nut M2.5 DIN934

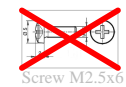

Screw M2.5x6

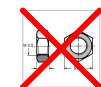

Nut M2.5 DIN934

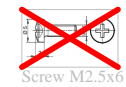

Screw M2.5x6

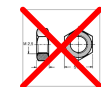

Nut M2.5 DIN934



Title: TE0703 – Overview

A4

Number: TE0703  
Default

Rev. 07

Date: 14.03.2024

Copyright: Trenz Electronic GmbH

Page 5 of 14

Filename: TE0703.SchDoc

A

A

B

B

C

C

D

D

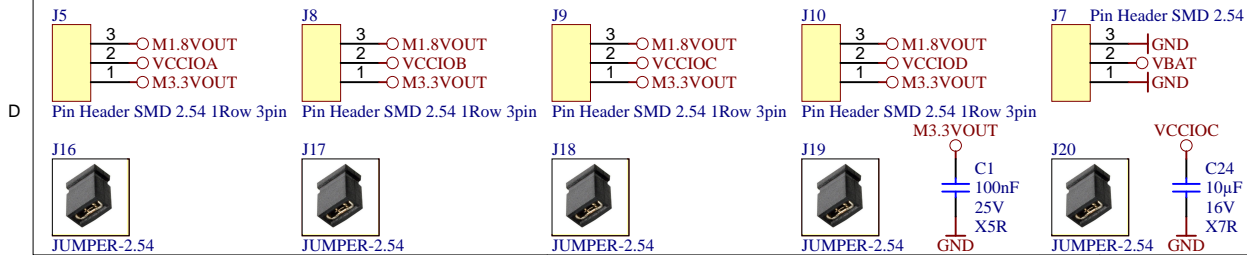
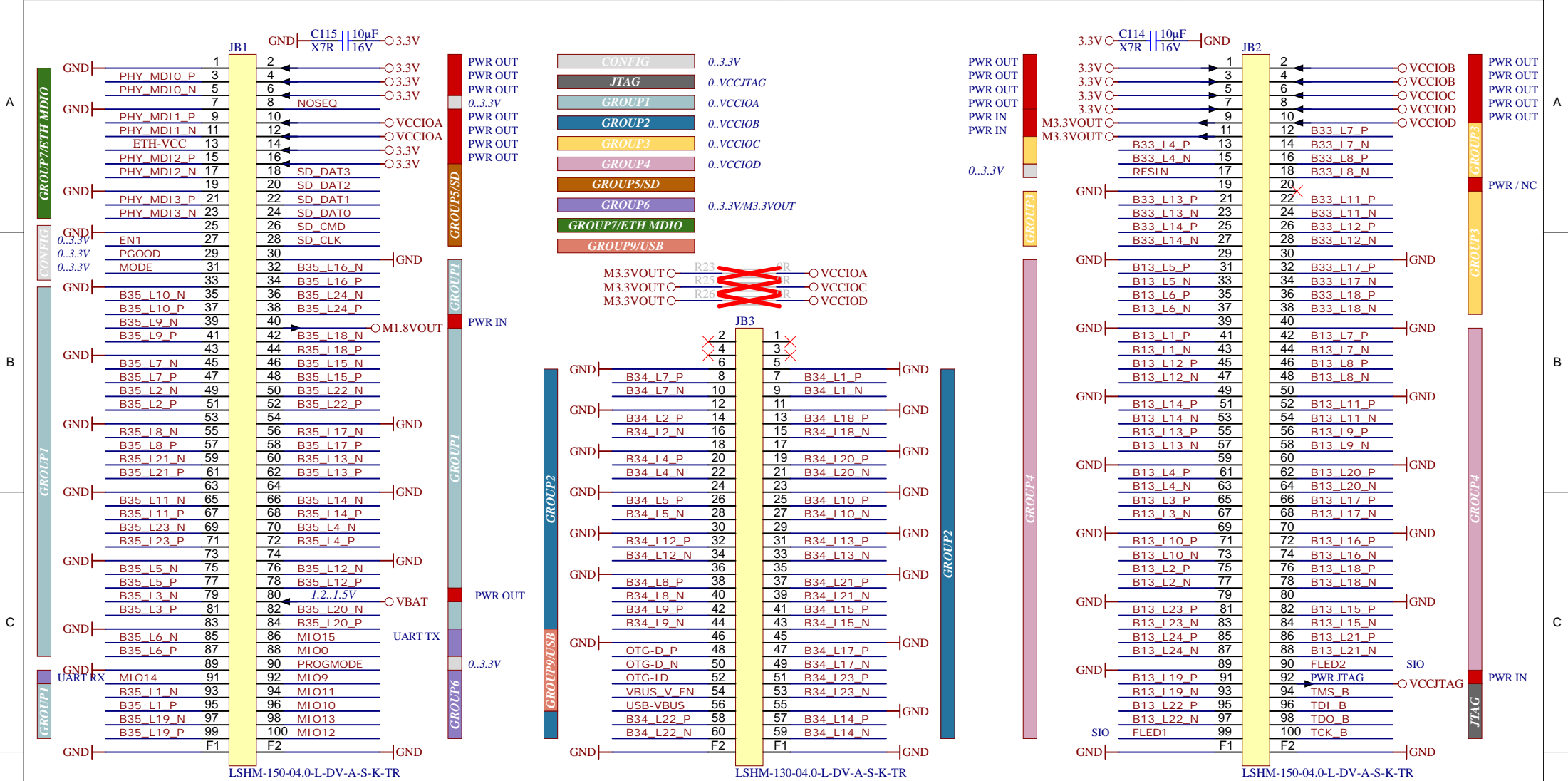

Title: <b>TE0703 – B2B Connector</b>		
A4	Number: <b>TE0703 Default</b>	Rev. <b>07</b>
Date: 14.03.2024	Copyright: Trenz Electronic GmbH	Page 6 of 14
Filename: <b>B2B_Connectors.SchDoc</b>		



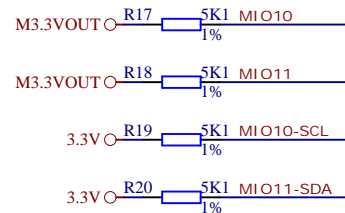
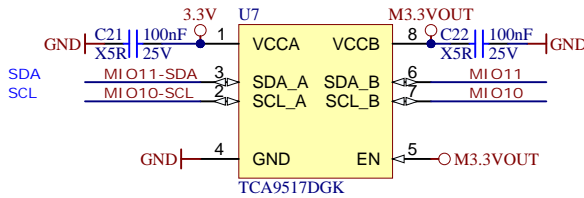
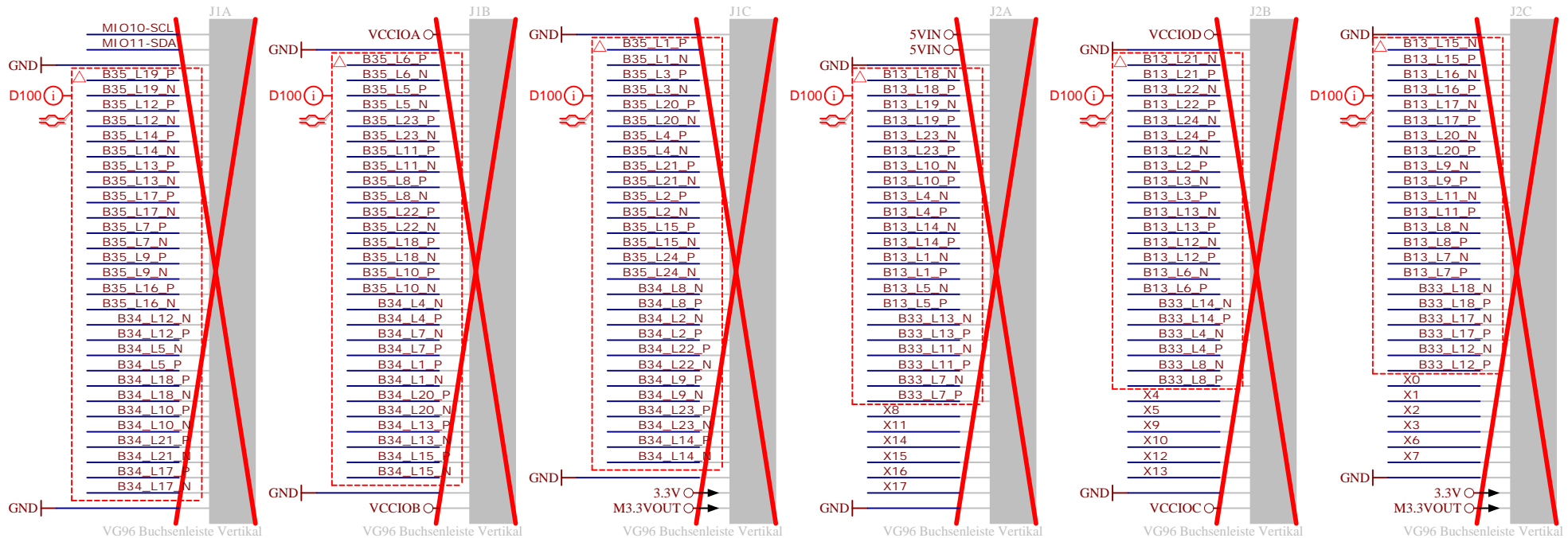

Title: TE0703 – External (VG96) Connector		
A4	Number: TE0703 Default	Rev. 07
Date: 14.03.2024	Copyright: Trenz Electronic GmbH	Page 7 of 14
Filename: VG_CONN.SchDoc		

1

2

3

4

A

A

B

B

C

C

D

D

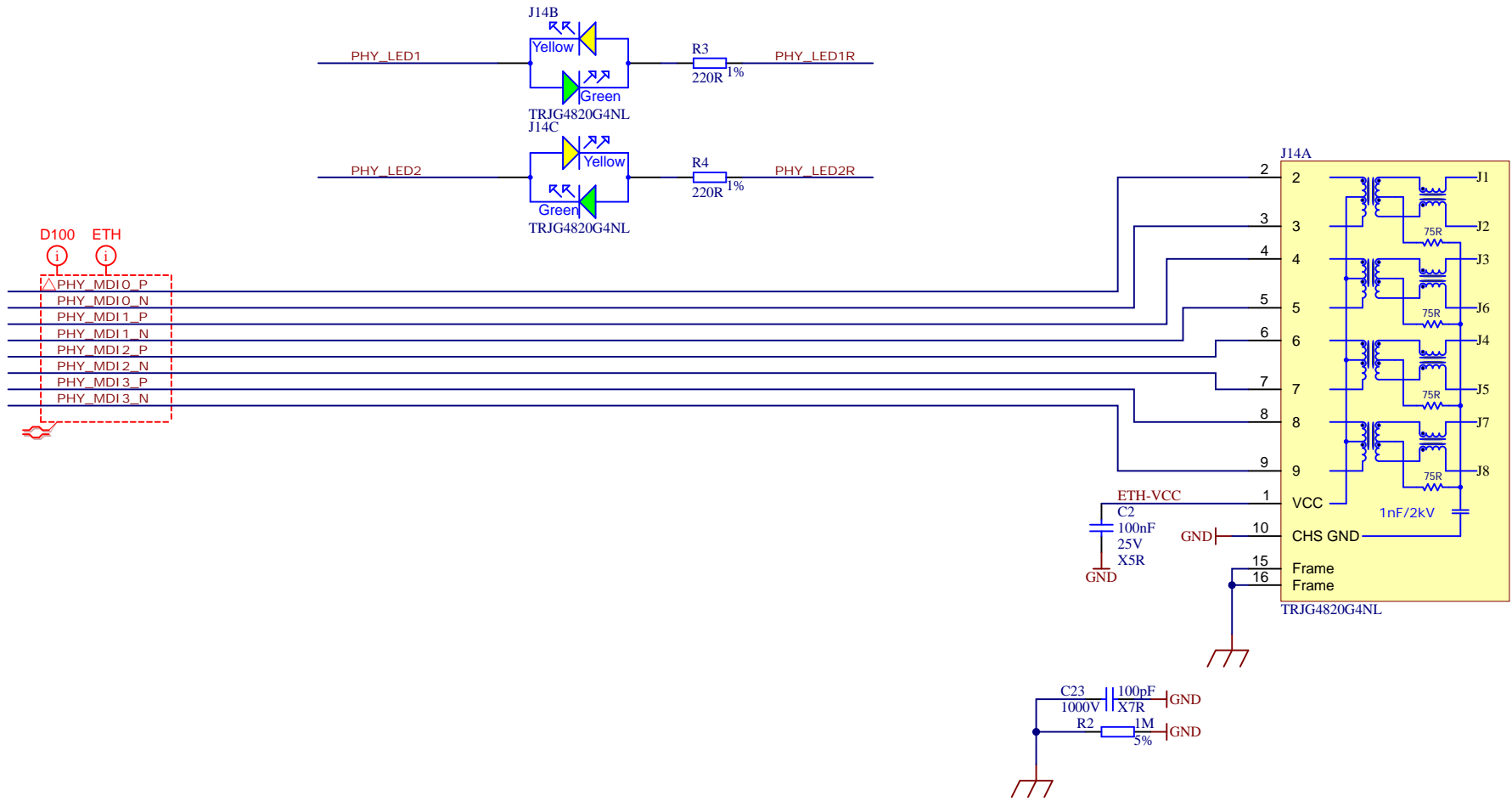

Title: TE0703 – Ethernet		
A4	Number: TE0703 Default	Rev. 07
Date: 14.03.2024	Copyright: Trenz Electronic GmbH	Page 8 of 14
Filename: Ethernet.SchDoc		

1

2

3

4



Variant	USB
Default	HOST
D	OTG

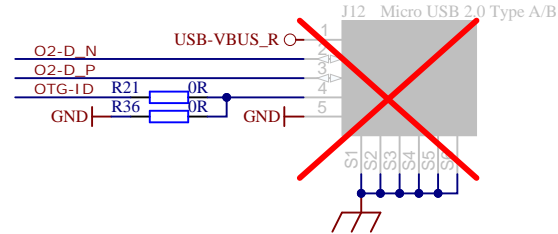
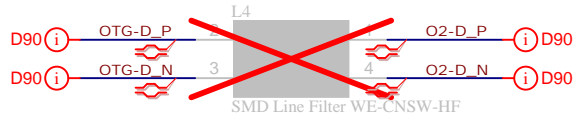
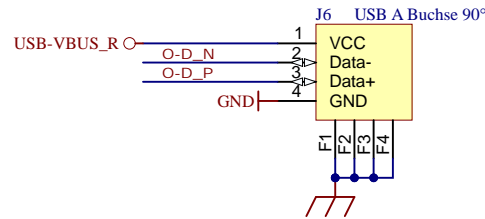
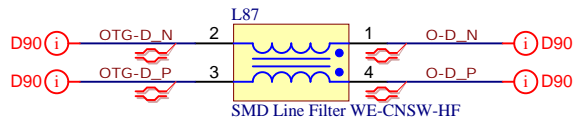
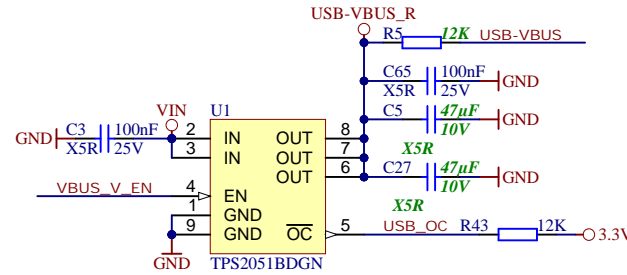

	Title: TE0703 – USB	
	A4	Number: TE0703 Default
	Date: 14.03.2024	Copyright: Trenz Electronic GmbH
	Rev. 07	Page 9 of 14
Filename: USB.SchDoc		

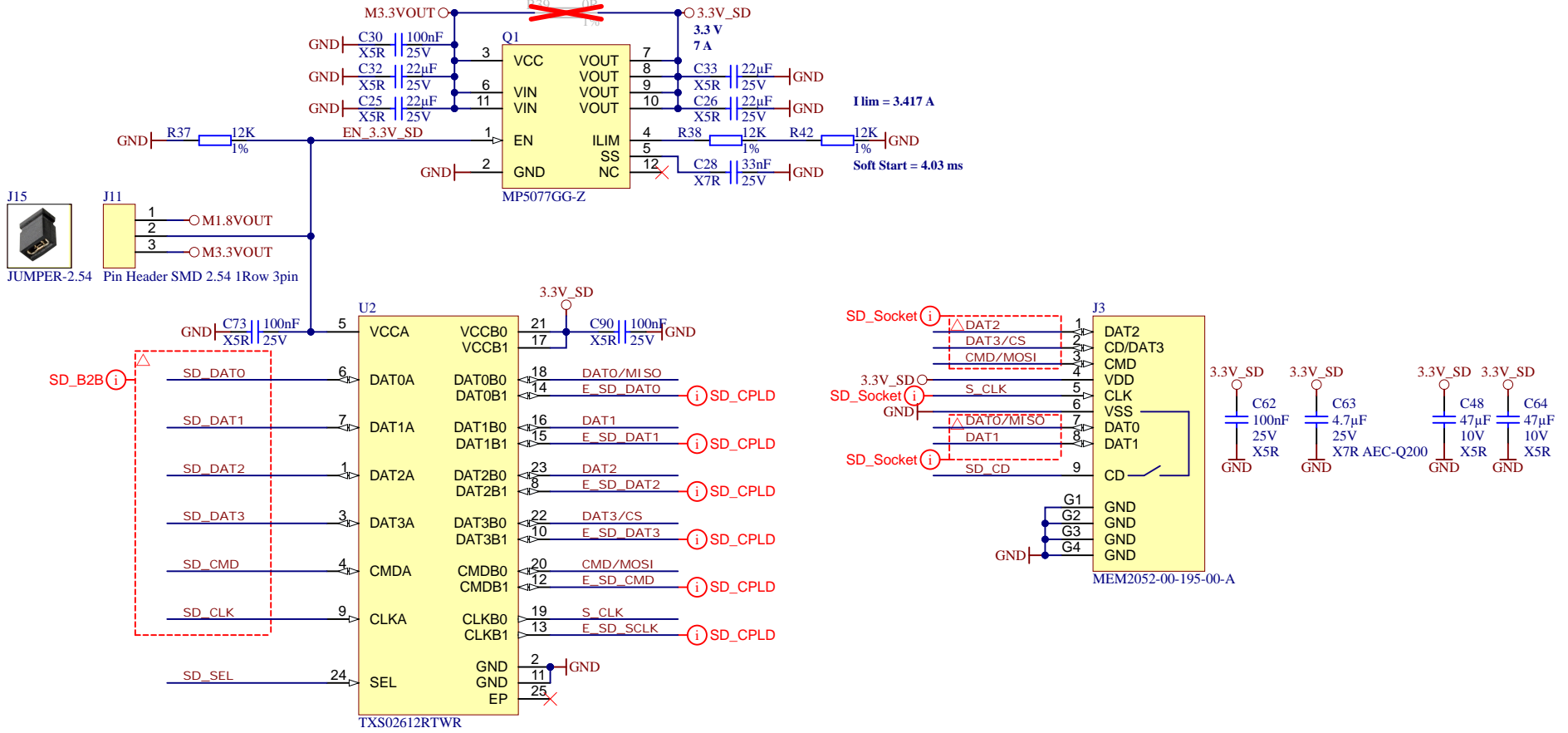

	Title: <b>TE0703 – SD Card</b>	
	A4	Number: <b>TE0703 Default</b>
	Date: 14.03.2024	Copyright: Trenz Electronic GmbH
	Page 10 of 14	Rev. <b>07</b>
Filename: <b>SDCard.SchDoc</b>		

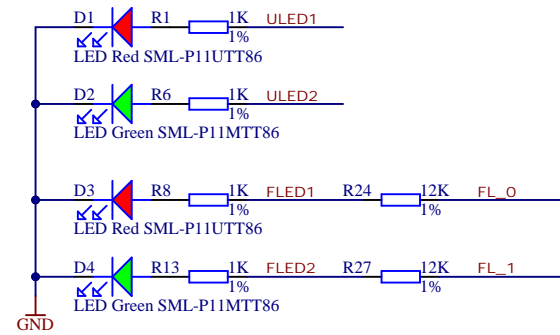
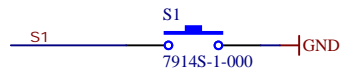
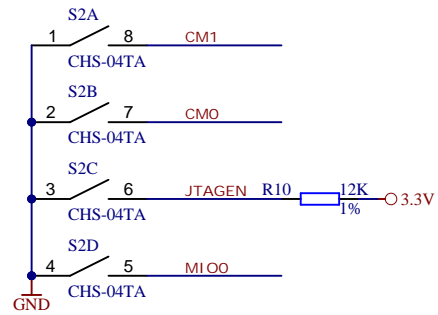

Title: TE0703 – LED-Switch		
A4	Number: TE0703 Default	Rev. 07
Date: 14.03.2024	Copyright: Trenz Electronic GmbH	Page 11 of 14
Filename: LED_SW_BUT.SchDoc		

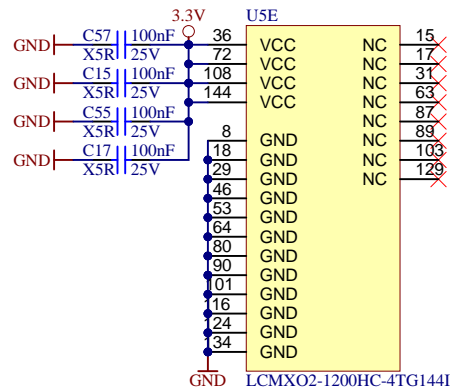
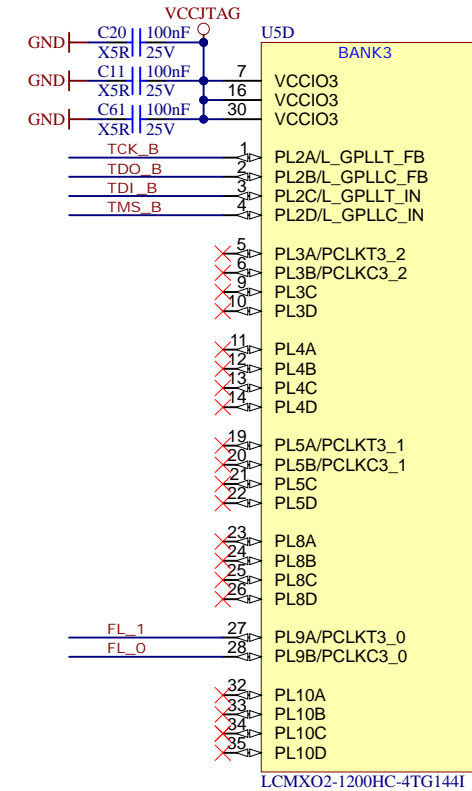
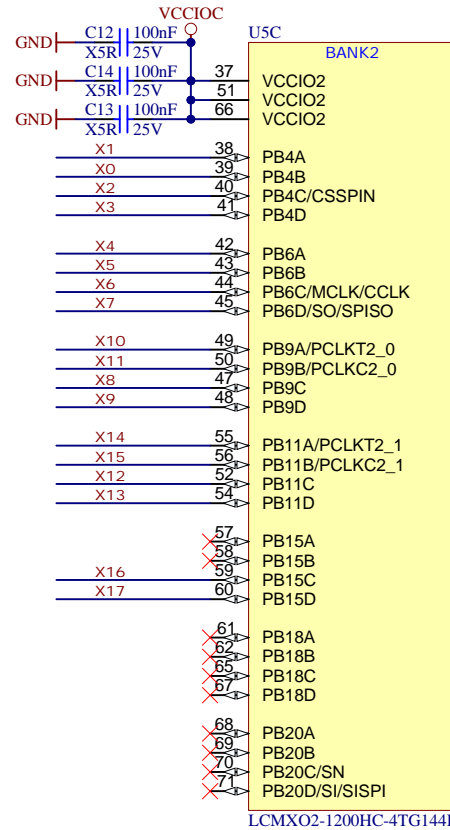
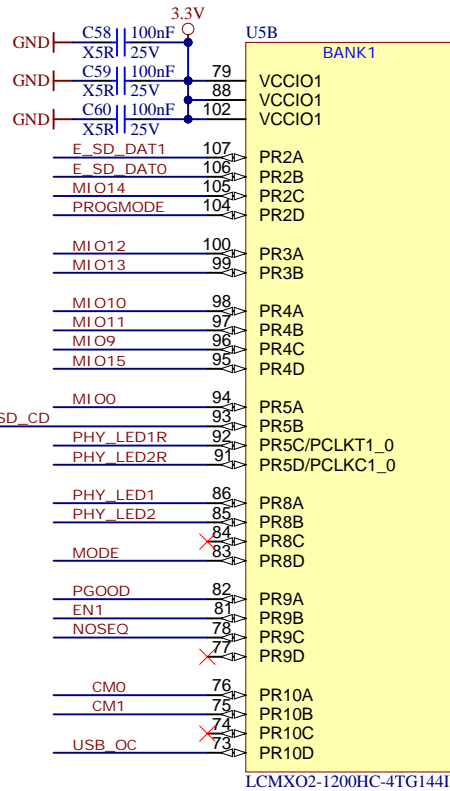
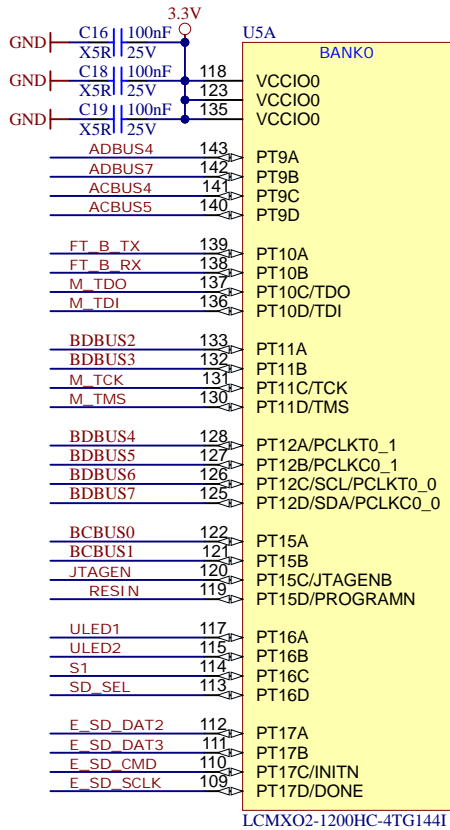

Title: TE0703 – System Controller		
A4	Number: TE0703 Default	Rev. 07
Date: 14.03.2024	Copyright: Trenz Electronic GmbH	Page 12 of 14
Filename: CPLD.SchDoc		

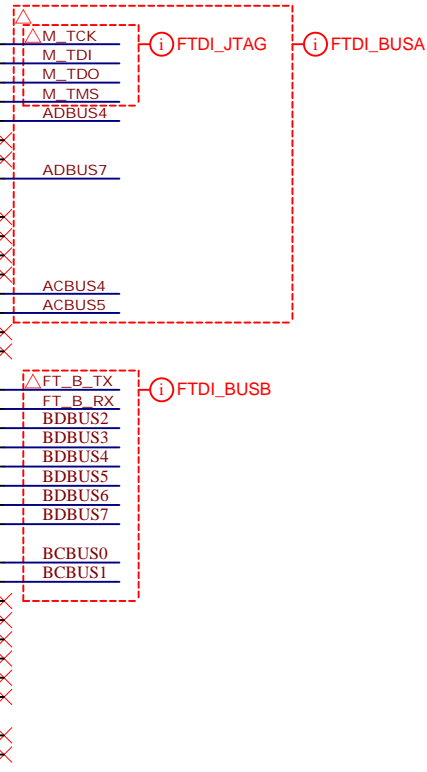
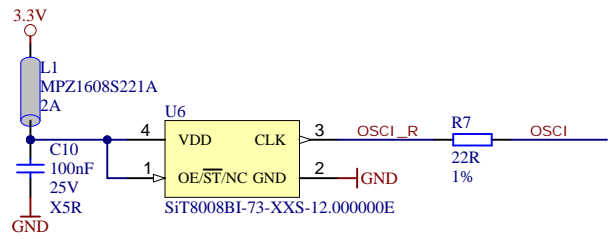
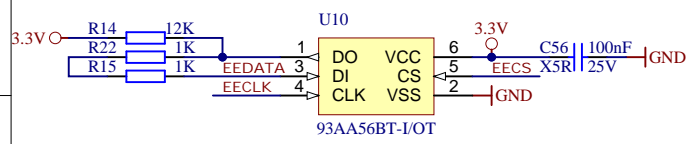
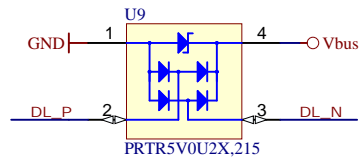
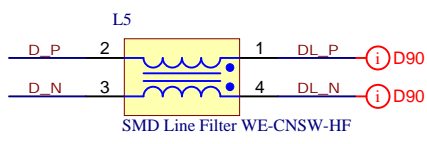
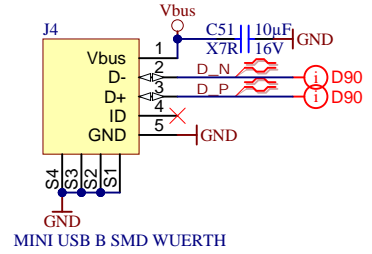
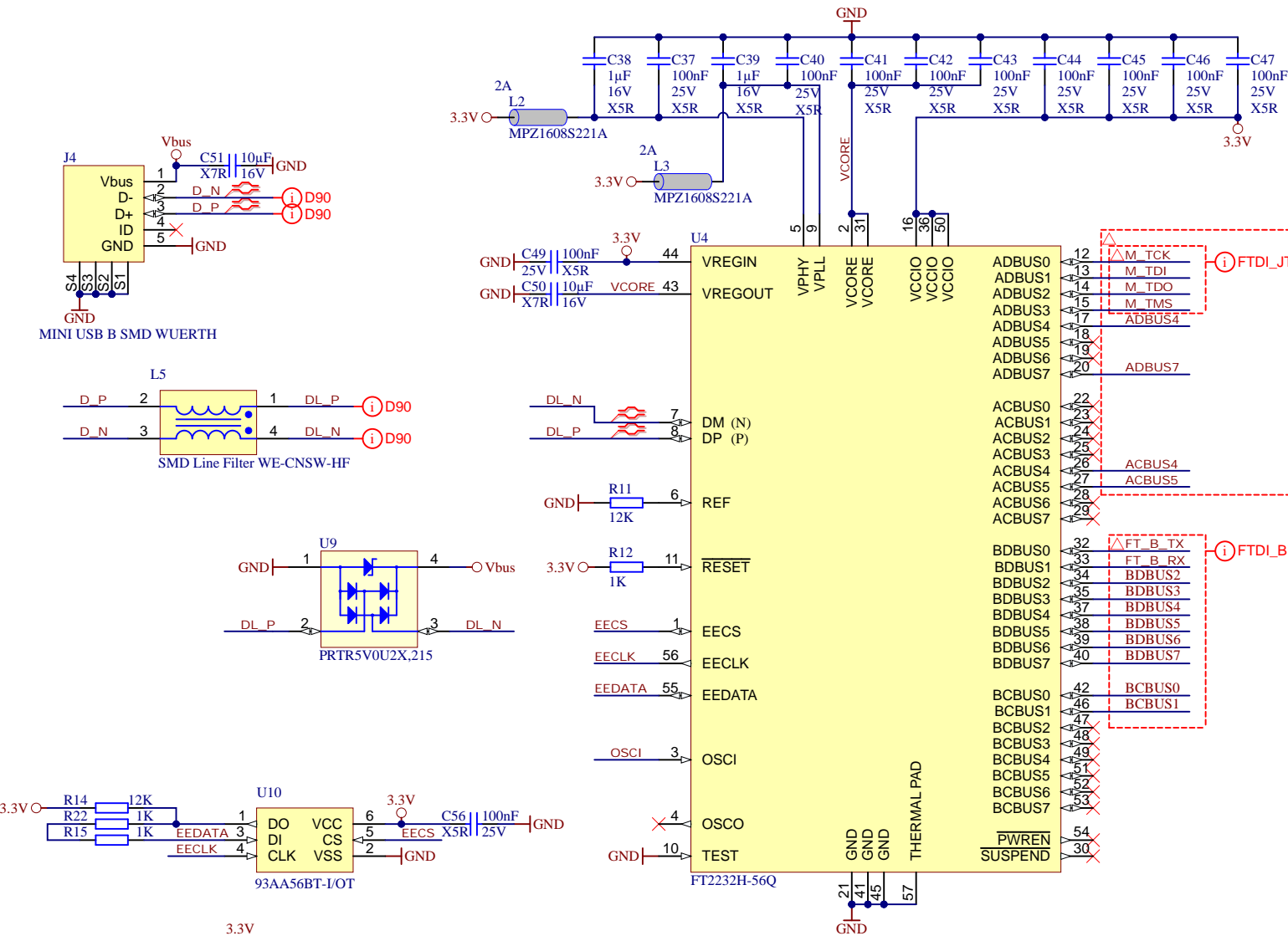

Title: TE0703 – USB-JTAG		
A4	Number: TE0703 Default	Rev. 07
Date: 14.03.2024	Copyright: Trenz Electronic GmbH	Page 13 of 14
Filename: FTDI.SchDoc		

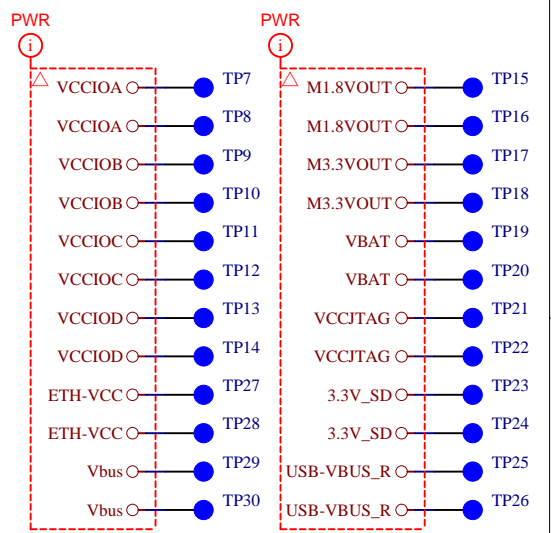
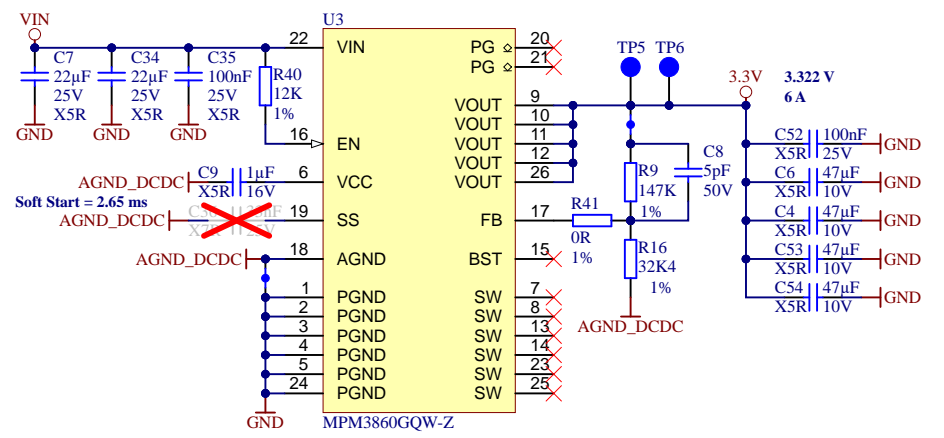
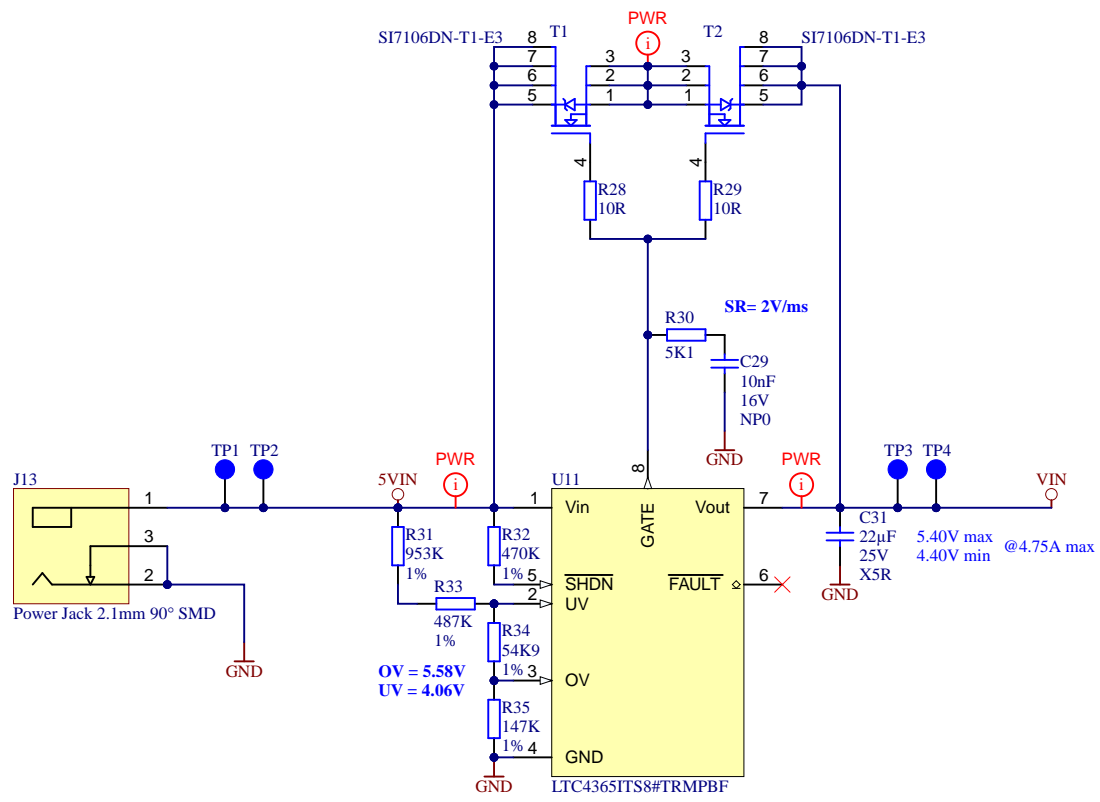

		Title: TE0703 – Power	
		A4	Number: TE0703 Default
Date: 14.03.2024		Copyright: Trenz Electronic GmbH	
Filename: POWER.SchDoc		Page 14 of 14	