

Regarding the usage of our schematics and alike documentation for Trenz module .

Project is protected under copyright and we strongly and strictly prohibit the reverse engineering or recreation, even if the design is just adapted or modified. TE0715 is protected under such right and in case of plagiarism we will have to do anything necessary in order to protect our assets.

Schematics and other handouts serve for informational purposes only!

	Title: TE0715 - Legal Notices Modules		
	A4	Number: TE0715 21C33-A	Rev. 05
	Date: 04.05.2022	Copyright: Trenz Electronic GmbH	Page 1 of 20
	Filename: Legal Notices Modules.SchDoc		

TE0715-05

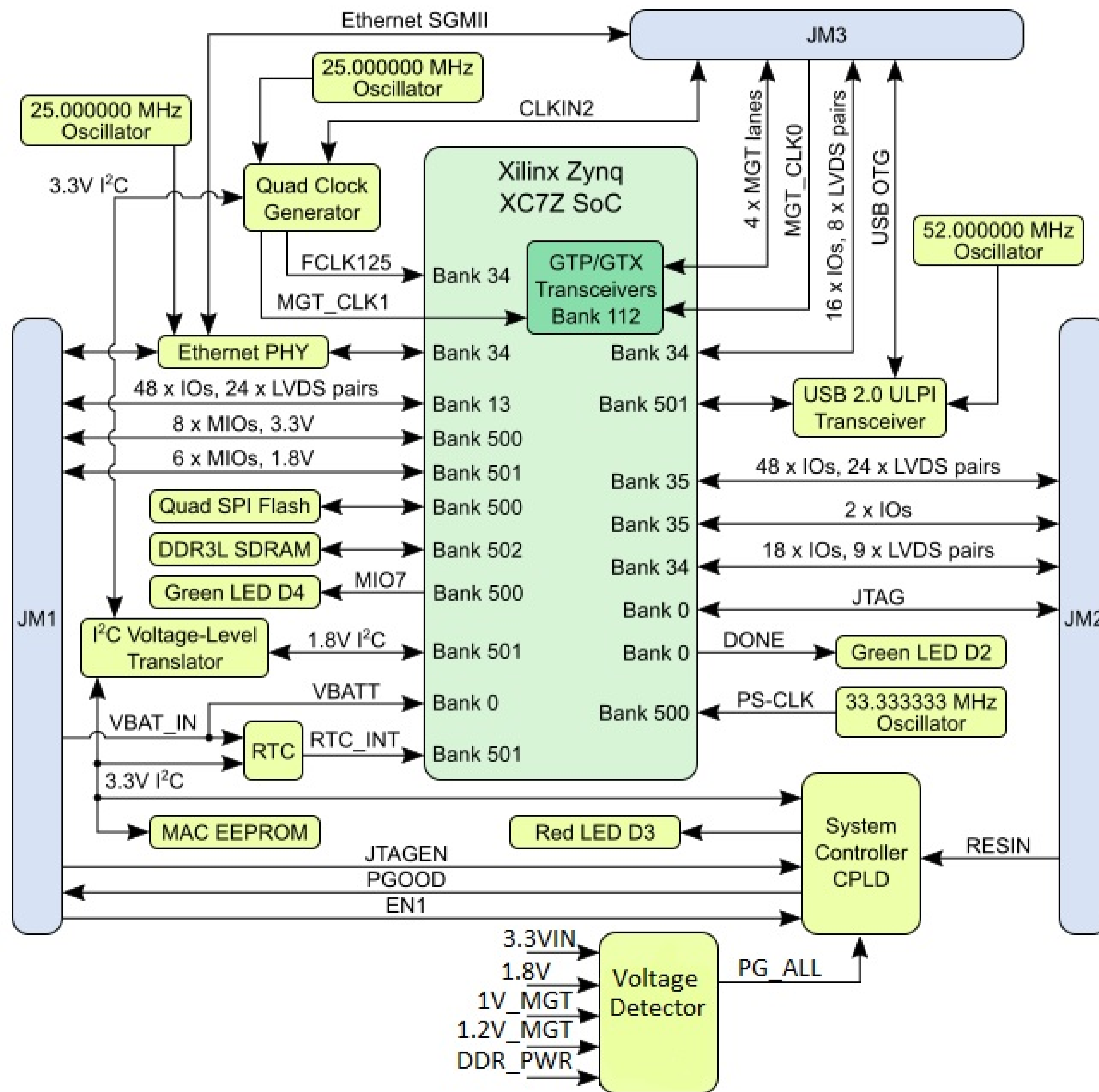

Title: TE0715 - System Overview		
A4	Number: TE0715 21C33-A	Rev. 05
Date: 04.05.2022	Copyright: Trenz Electronic GmbH	Page 2 of 20
Filename: Overview.SchDoc		

REV	Description	
-01	Initial revision	
-02		
-03		
-04		
-05	<p>1. Revised power supply circuit: replaced obsolete parts U1, U2, U3,U8,U24, Q1</p> <p>2. Added power supervisor BD39040MUF (U25). Signal PG_DDR_PWR renamed to PG_All (U25) and connected to system controller (U26.27)</p> <p>3. Signal MIO8 (U5.E18) connected to system controller (U26.8)</p> <p>4. Power supervisor U23 connected to 3.3VIN power rail (was 3.3V). Added protection diode D5 to U23.3 (#MR input)</p> <p>5. Revised quantity of decoupling capacitors regarding Xilinx Spec (UG933, v1.13.1)</p> <p>6. Remove GND connection from "RSVDGND" (U5.G12, Xilinx Spec UG865 v1.9)</p> <p>7. Auxiliary information has been added on Overview, Power_diagram, Legal_Notices pages</p> <p>8. PCB: Revised layout of power supplies</p> <p>9. PCB: Revised layout of Samtec B2B signals. The length of the tracks has been changed. Pinout of Samtec B2B connectors not affected</p> <p>10. SCH & PCB: Full LIB update</p>	VT



Title: TE0715 - Revision History		
A4	Number: TE0715 21C33-A	Rev. 05
Date: 04.05.2022	Copyright: Trenz Electronic GmbH	Page 3 of 20
Filename: Revision Changes.SchDoc		

Power-on sequencing:

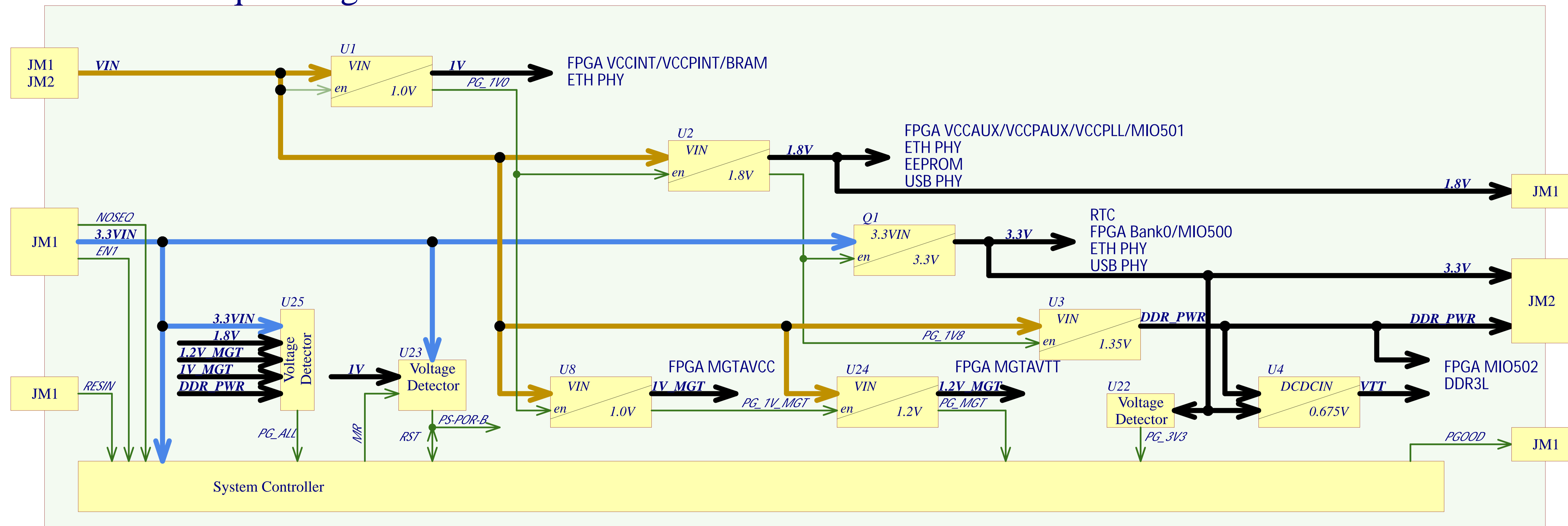

Supported Voltage Ranges:

Power Rail	Direction	Range	Tolerance	Description	Note
VIN	IN	3.3 - 5V	+/-5%	Micromodule Power	-
3.3VIN	IN	3.3V	+/-5%	Micromodule Power	-
VCCIO13	IN	1.2 - 3.3V	+/-3%	HR IO Bank13	-
VCCIO34	IN	1.2 - 3.3V	+/-3%	HR IO Bank34	for XC7Z012/XC7Z015
VCCIO34	IN	1.2 - 1.8V	+/-3%	HP IO Bank34	for XC7Z030
VCCIO35	IN	1.2 - 3.3V	+/-3%	HR IO Bank35	for XC7Z012/XC7Z015
VCCIO35	IN	1.2 - 1.8V	+/-3%	HP IO Bank35	for XC7Z030
VBAT_IN	IN	3.0V	+/-3%	RTC	-
1.8V	OUT	1.8V	+/-3%	Power for Carrier	-
3.3V	OUT	3.3V	+/-3%	Power for Carrier	-
DDR_PWR	OUT	1.35V	+/-3%	Power for Carrier	-

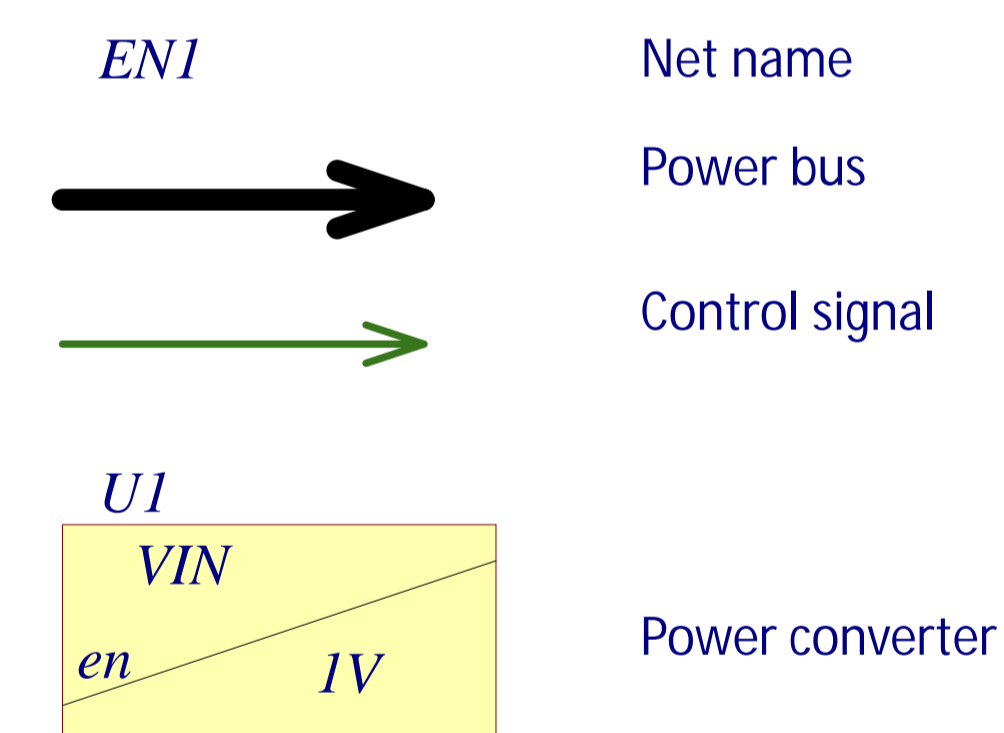

Title: TE0715 - Power Diagram		
A4	Number: TE0715 21C33-A	Rev. 05
Date: 04.05.2022	Copyright: Trenz Electronic GmbH	Page 4 of 20
Filename: Power_Diagram.SchDoc		

1

2

3

4

- FPGA-MISC
- FPGA-MISC.SchDoc
- B13
- B13.SchDoc
- B34
- B34.SchDoc
- B35
- B35.SchDoc
- MIO-BANKS
- MIO-BANKS.SchDoc
- MGT
- MGT.SchDoc
- DDR-BANK
- DDR-BANK.SchDoc
- FPGA-POWER
- FPGA-POWER.SchDoc
- DDR3-RAM
- DDR3-RAM.SchDoc
- B2B_Connector
- B2B_Connector.SchDoc
- Clock
- Clock.SchDoc
- ETH-PHY
- ETH-PHY.SchDoc
- USB-PHY
- USB-PHY.SchDoc
- POWER
- POWER.SchDoc
- POWER_2
- POWER_2.SchDoc

Special notes:

Mount.Hole 3.2mm Mount.Hole 3.2mm

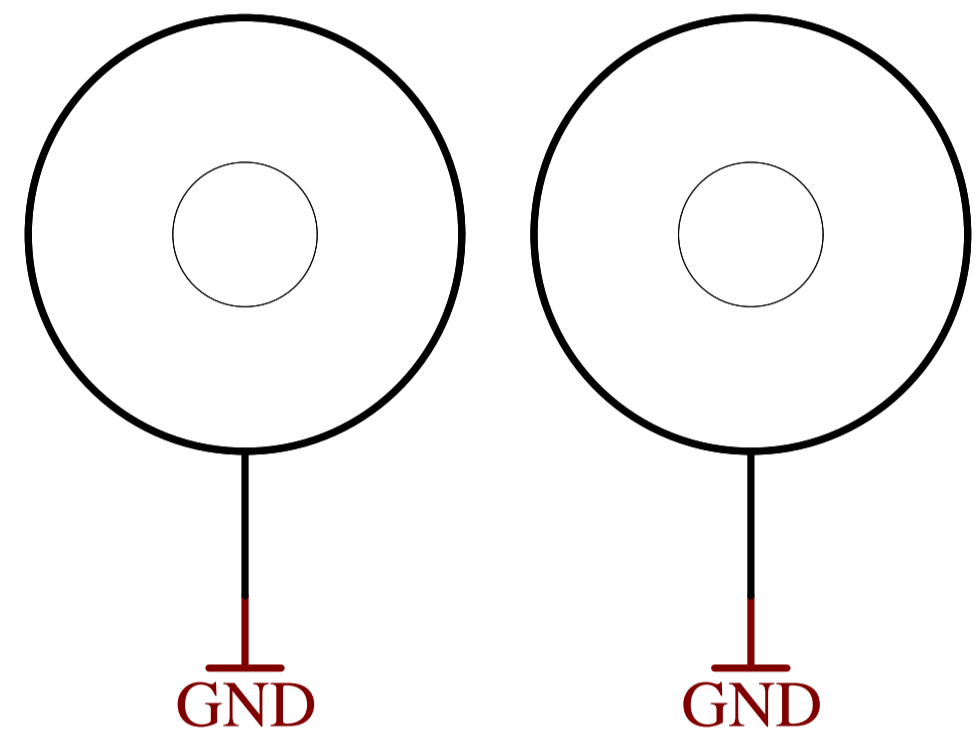

Mount.Hole 3.2mm Mount.Hole 3.2mm

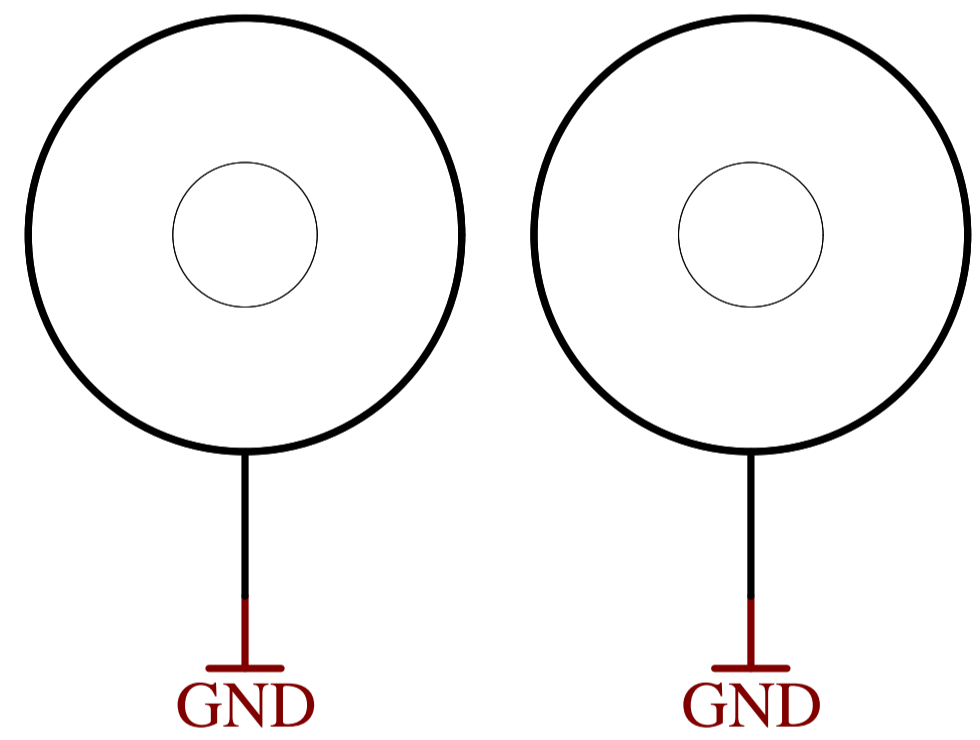

FIDU-DOT - mini FIDU-DOT - mini

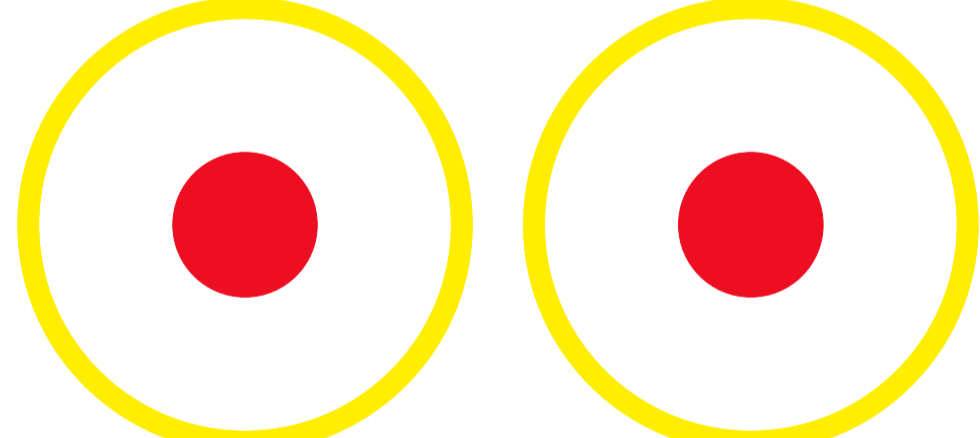

PM1 PM2
FIDU-DOT - mini FIDU-DOT - mini

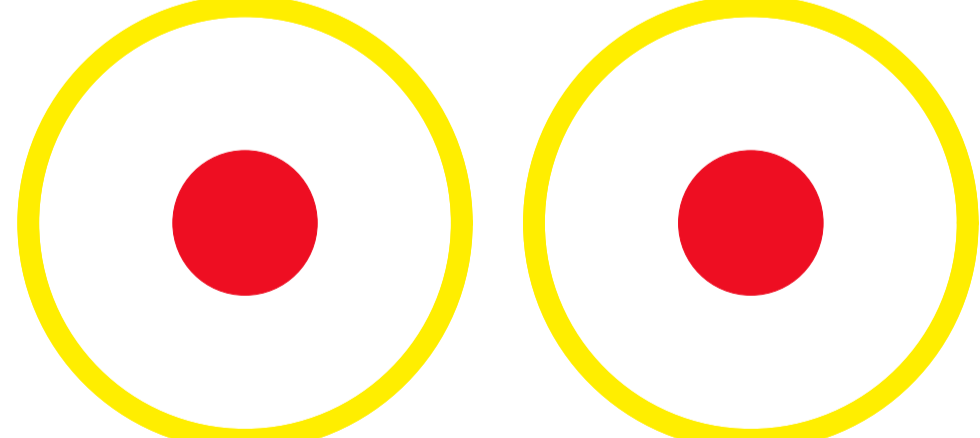

PM4 PM5
FIDU-DOT - mini FIDU-DOT - mini

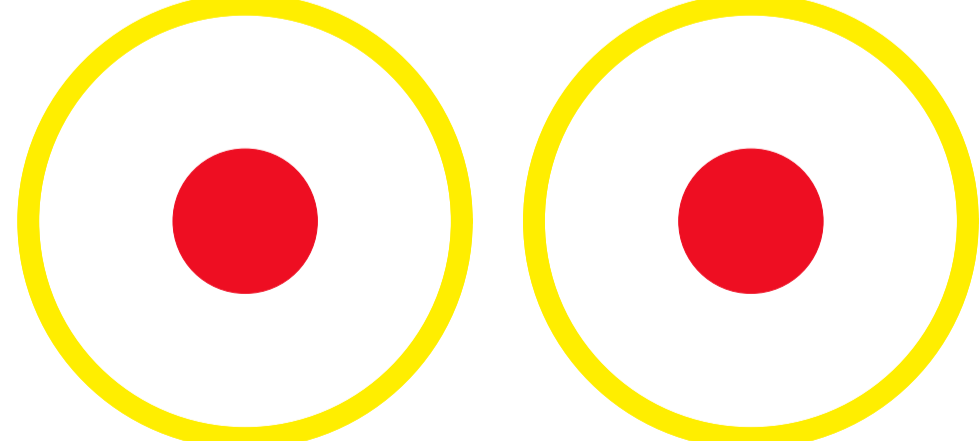

PM6 PM3

Serial
Serial
Serialnumber 6,3 x 6.3mm

Assembly variant: 21C33-A
 Created by: VT
 Modified by: MR
 Modified at: 2024-04-30



Title: TE0715 - Overview		
A4	Number: TE0715 21C33-A	Rev. 05
Date: 04.05.2022	Copyright: Trenz Electronic GmbH	Page 5 of 20
Filename: TE0715.SchDoc		

1

2

3

4

B13 48 IO, 24 LVDS Pairs
 MIO0 8 IO, 3.3V
 MIO1 6 IO 1.8V
 ETH MDI Copper

NOTE: B34 and B35 are HP Banks in 7030 Assembly with max 1.8V I/O Voltage

B34 16 IO, 8 LVDS Pairs
 USB OTG ETH SGMII
 PLL CLK I N
 GT CLK I N
 GTP/GTX 4 Lanes

B34 18 IO, 9 LVDS Pairs
 B35 48 IO, 24 LVDS Pairs
 B35 2 IO

A

A

B

B

C

C

D

D

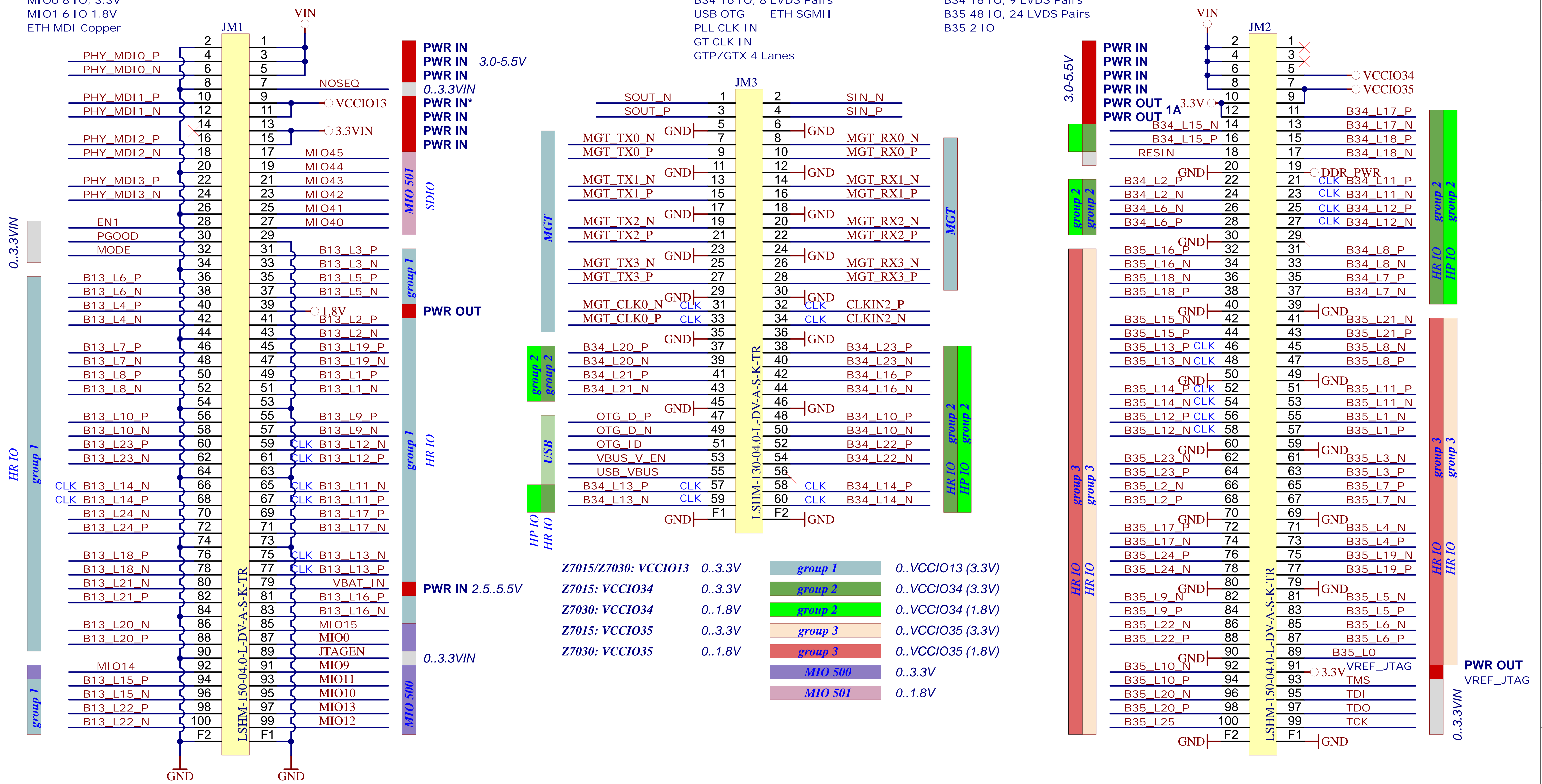

Top of Board

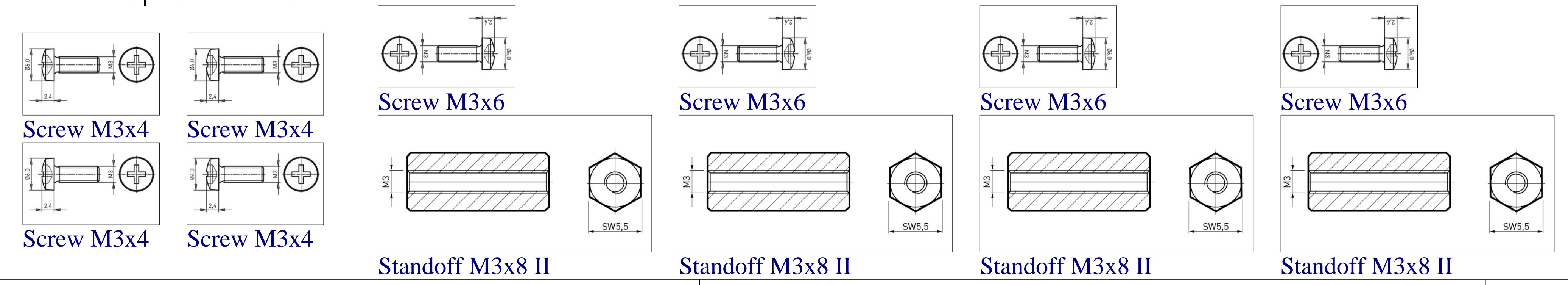

Title: TE0715 - B2B_Connectors		
A4	Number: TE0715 21C33-A	Rev. 05
Date: 04.05.2022	Copyright: Trenz Electronic GmbH	Page 6 of 20
Filename: B2B_Connector.SchDoc		

1

2

3

4

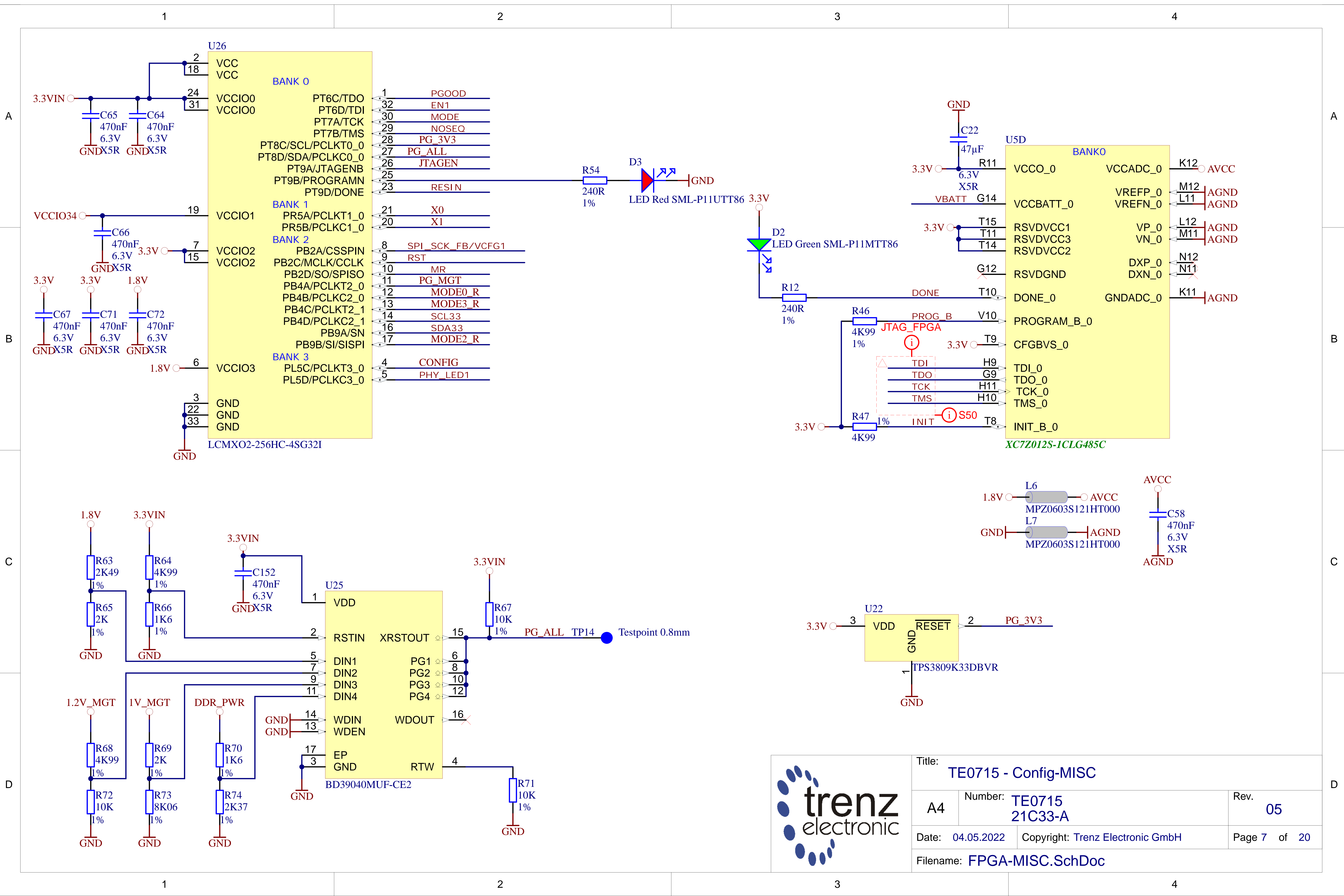

Title: TE0715 - Config-MISC		
A4	Number: TE0715 21C33-A	Rev. 05
Date: 04.05.2022	Copyright: Trenz Electronic GmbH	Page 7 of 20
Filename: FPGA-MISC.SchDoc		

HW Revision History

Revision	Pin "T16"	Pin "U16"
REV01	Floating	Floating
REV02	Floating	Floating
REV03	Floating	Floating
REV04	GND	Floating
REV05	Floating	GND

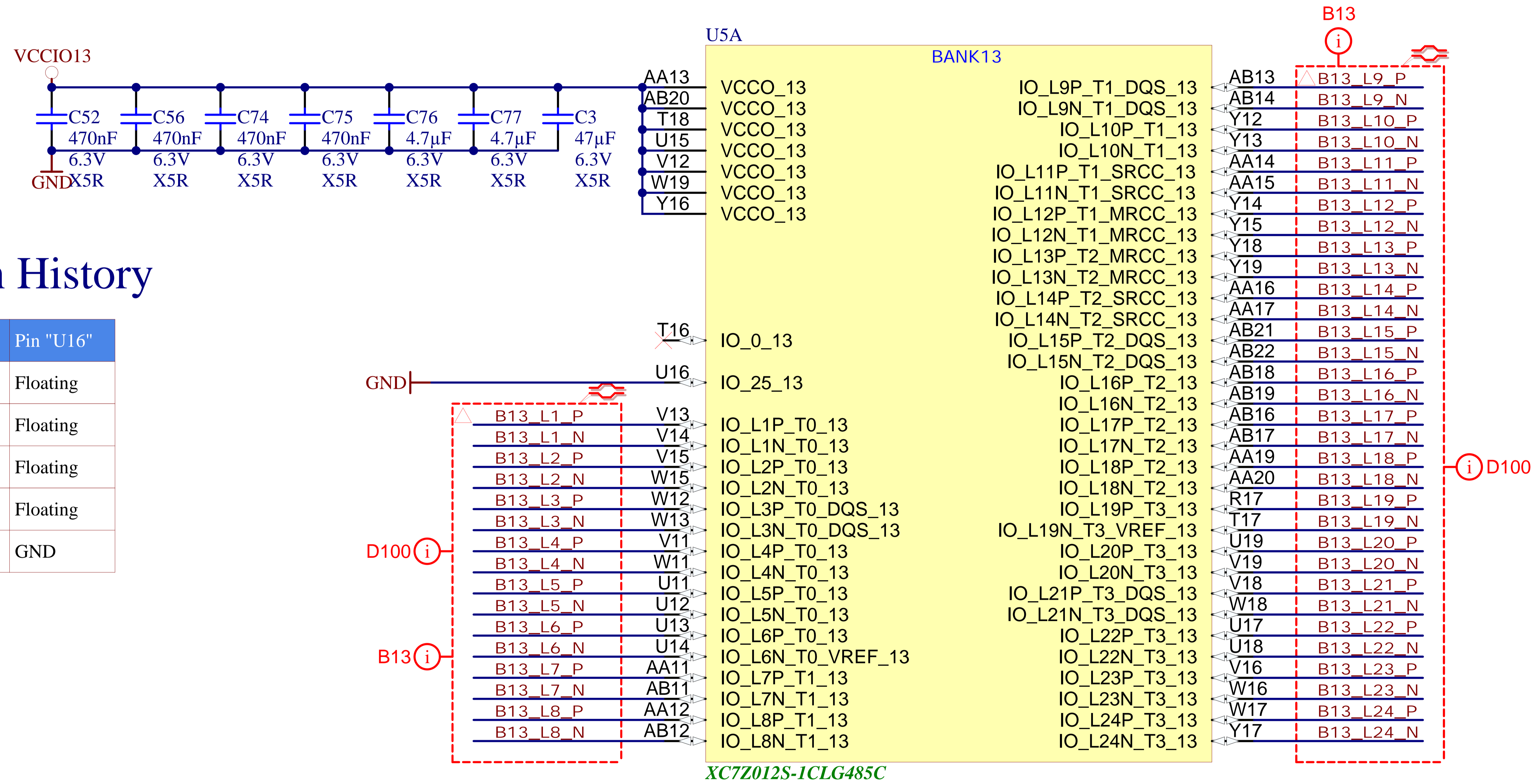

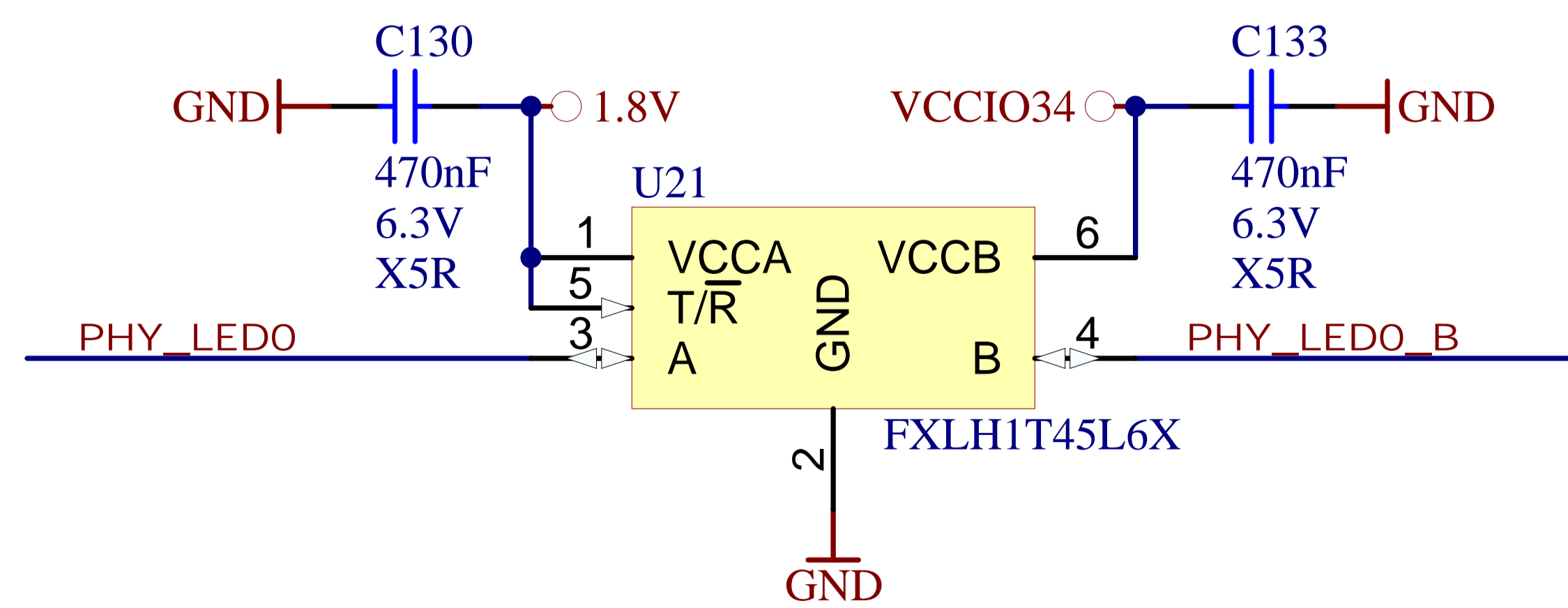
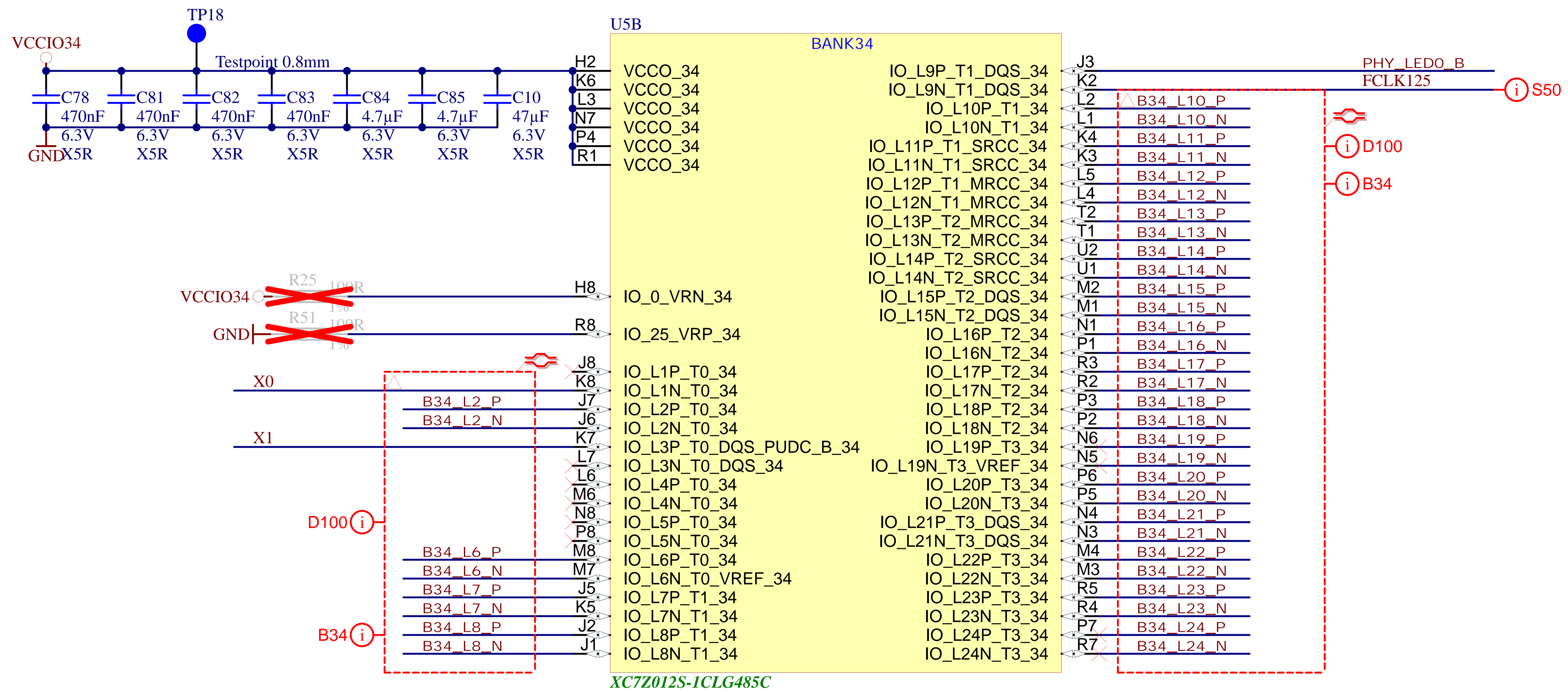

Title: **TE0715 - FPGA_B12**

A4	Number: TE0715 21C33-A	Rev. 05
Date: 04.05.2022	Copyright: Trenz Electronic GmbH	Page 8 of 20
Filename: B13.SchDoc		

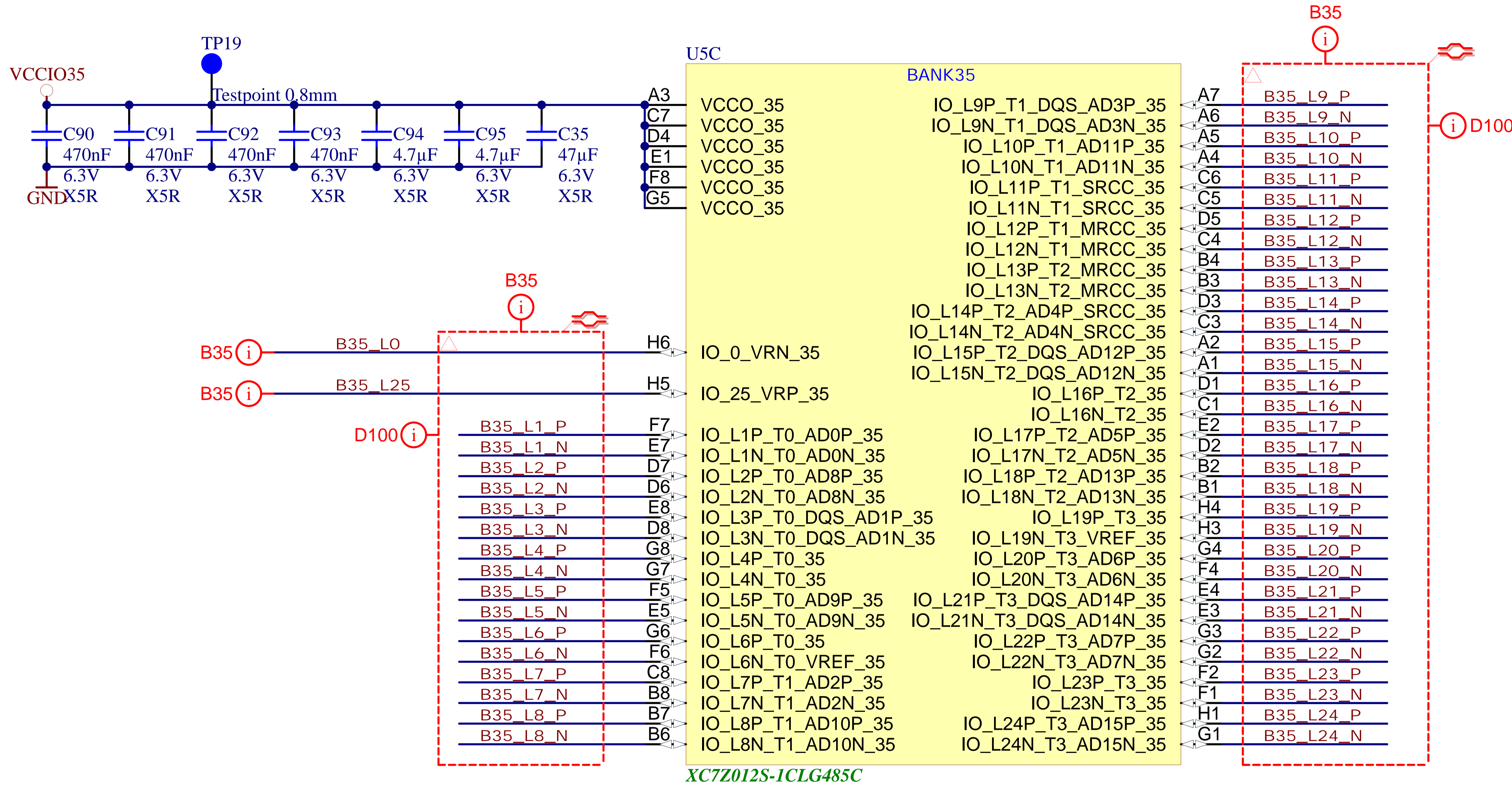

Title: TE0715 - FPGA_B34		
A4	Number: TE0715 21C33-A	Rev. 05
Date: 04.05.2022	Copyright: Trenz Electronic GmbH	Page 9 of 20
Filename: B34.SchDoc		

Title: TE0715 - FPGA_B35		
A4	Number: TE0715 21C33-A	Rev. 05
Date: 04.05.2022	Copyright: Trenz Electronic GmbH	Page 10 of 20
Filename: B35.SchDoc		

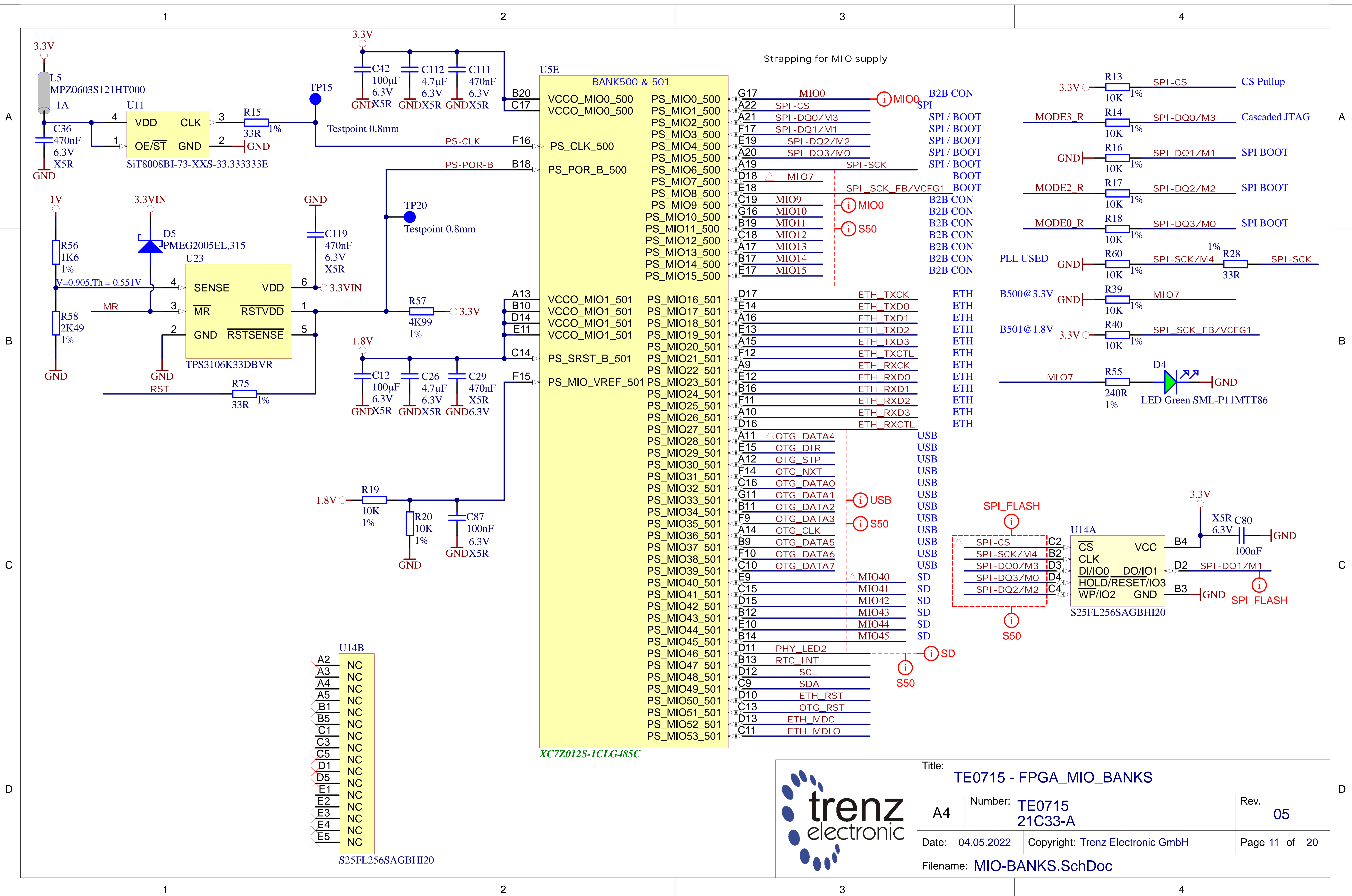

Title: **TE0715 - FPGA_MIO_BANKS**

A4 Number: **TE0715 21C33-A** Rev. **05**

Date: 04.05.2022 Copyright: Trenz Electronic GmbH Page 11 of 20

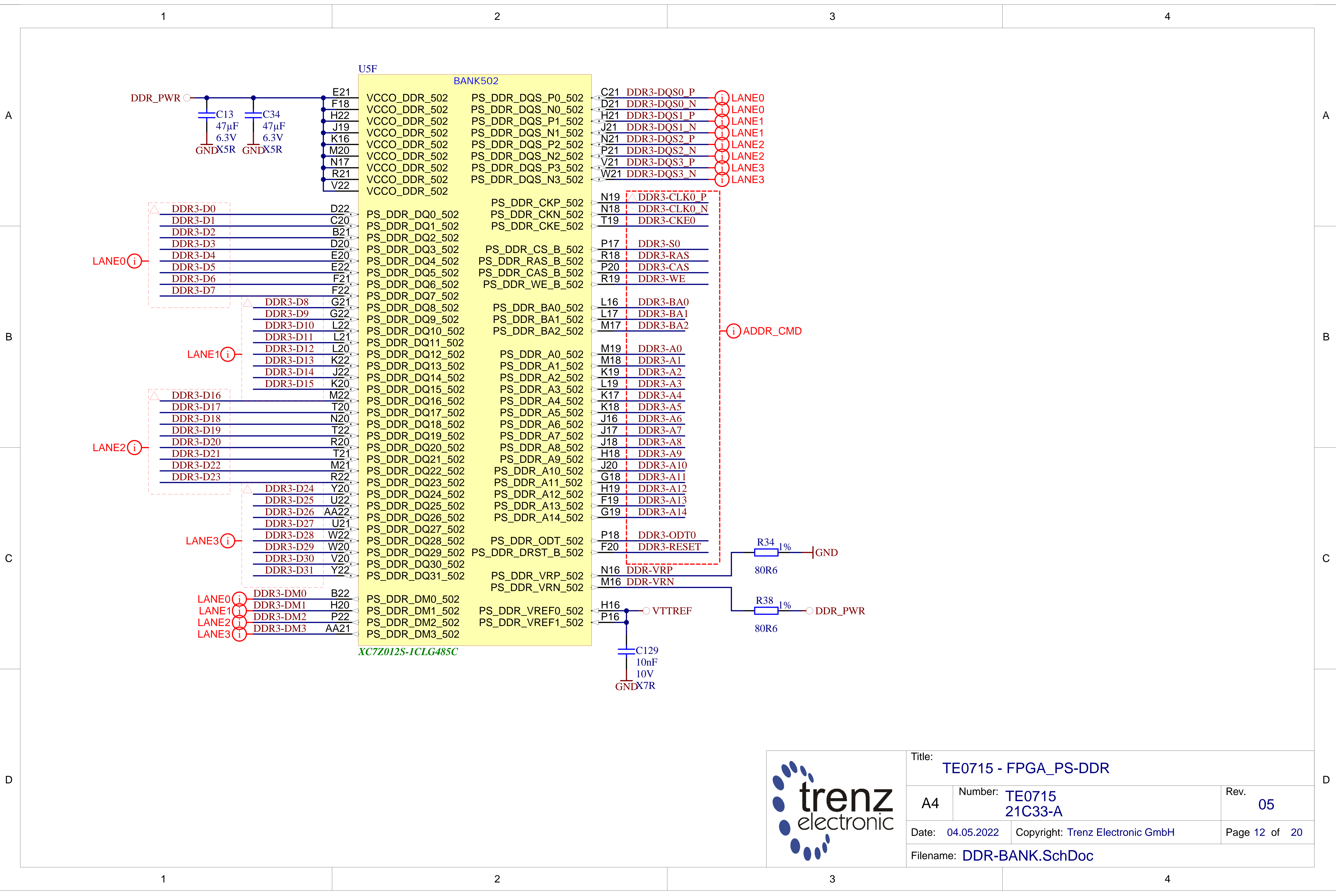

Filename: **MIO-BANKS.SchDoc**

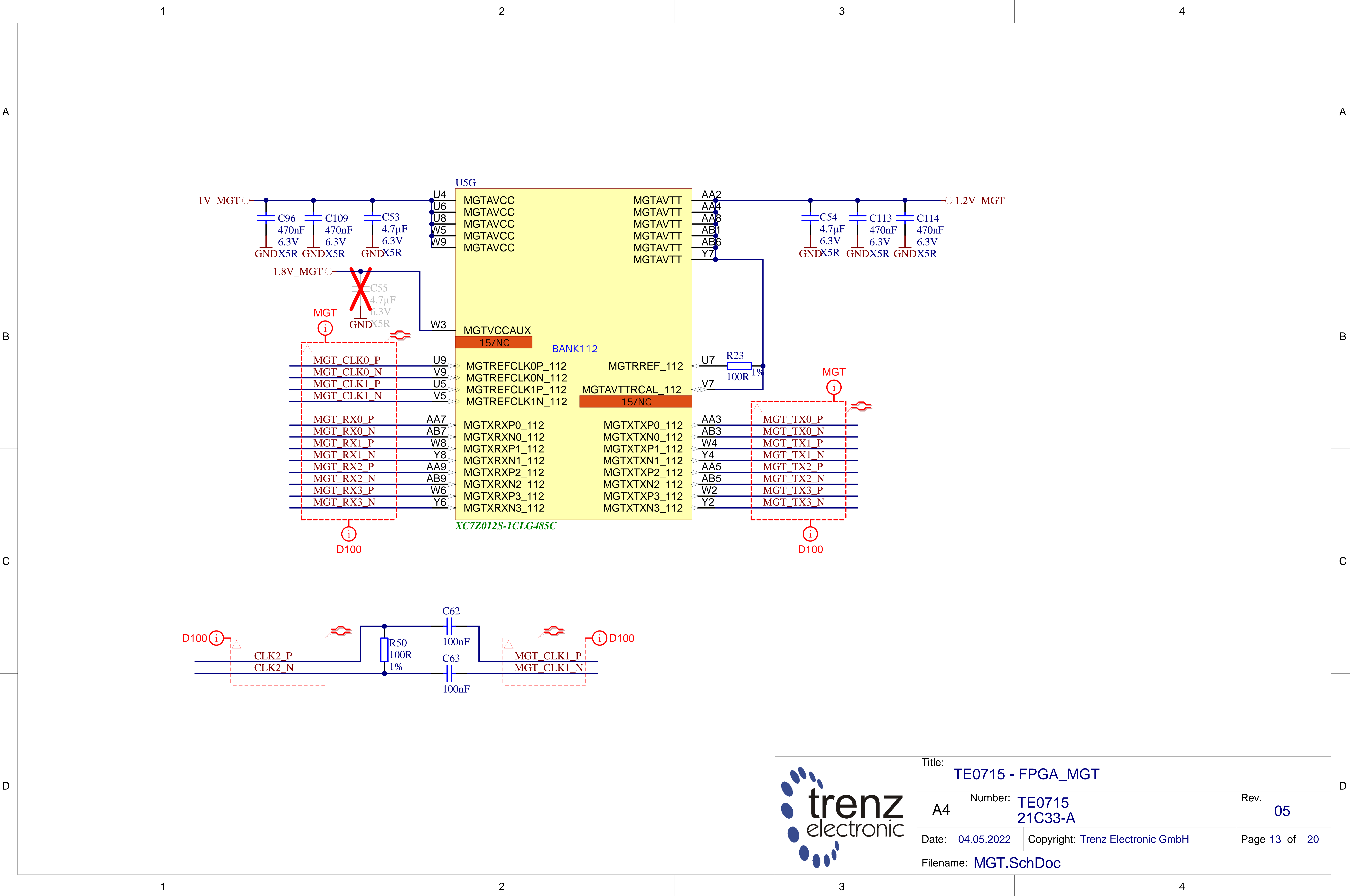

Title: TE0715 - FPGA_PS-DDR		
A4	Number: TE0715 21C33-A	Rev. 05
Date: 04.05.2022	Copyright: Trenz Electronic GmbH	Page 12 of 20
Filename: DDR-BANK.SchDoc		

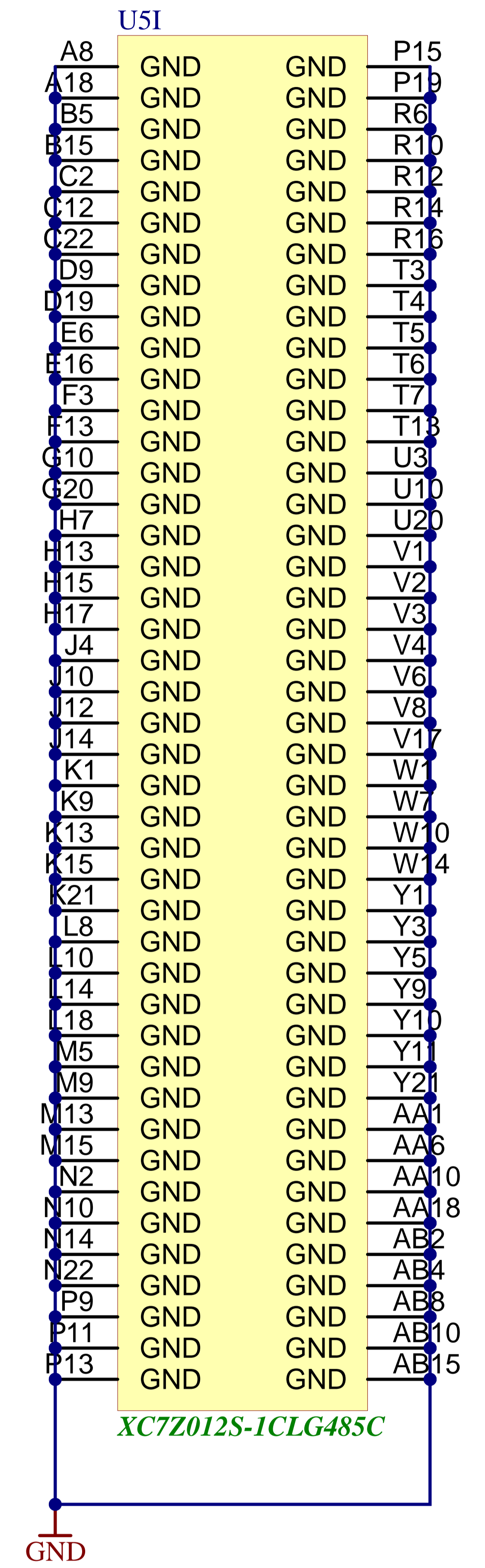
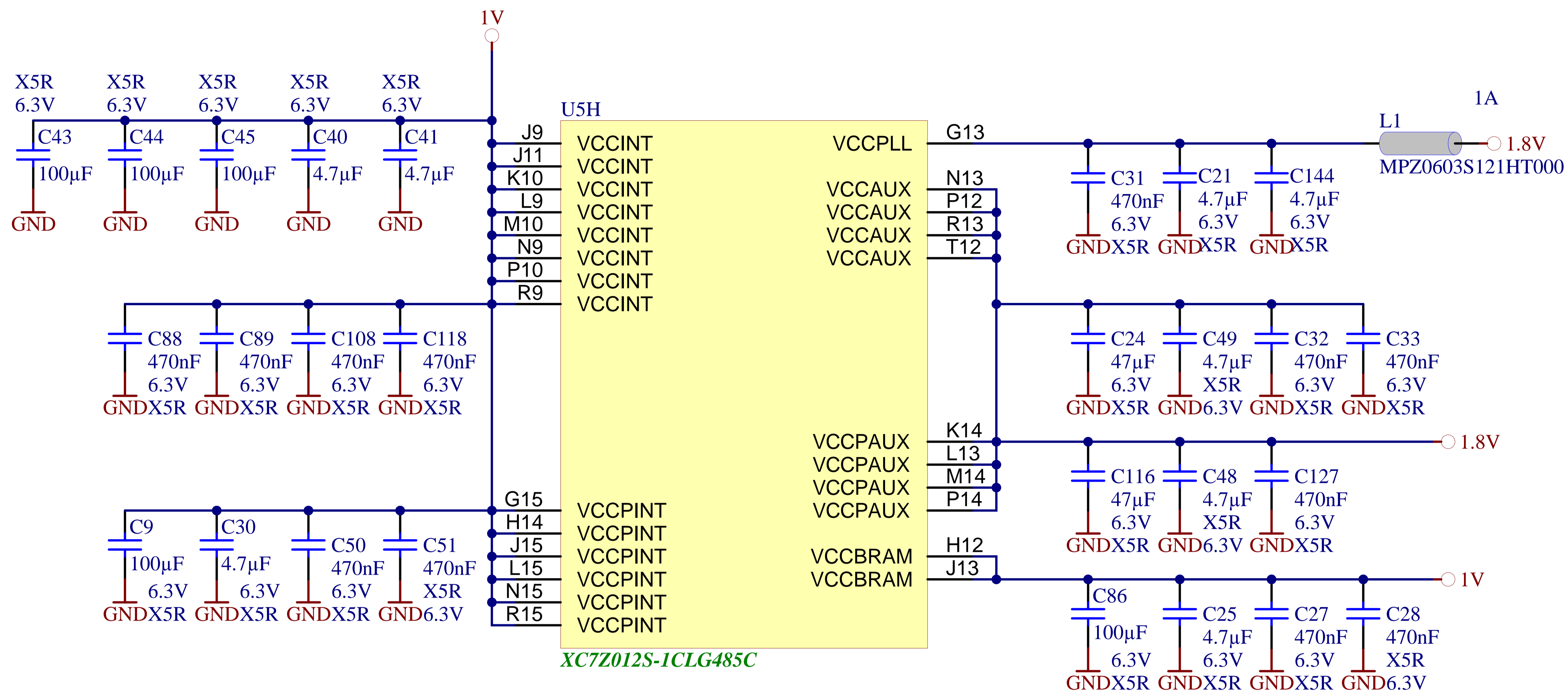

		Title: TE0715 - FPGA_MGT	
		A4 Number: TE0715 21C33-A	Rev. 05
Date: 04.05.2022		Copyright: Trenz Electronic GmbH	
Filename: MGT.SchDoc			
Page 13 of 20			

Title: TE0715 - FPGA_Power		
A4	Number: TE0715 21C33-A	Rev. 05
Date: 04.05.2022	Copyright: Trenz Electronic GmbH	Page 14 of 20
Filename: FPGA-POWER.SchDoc		

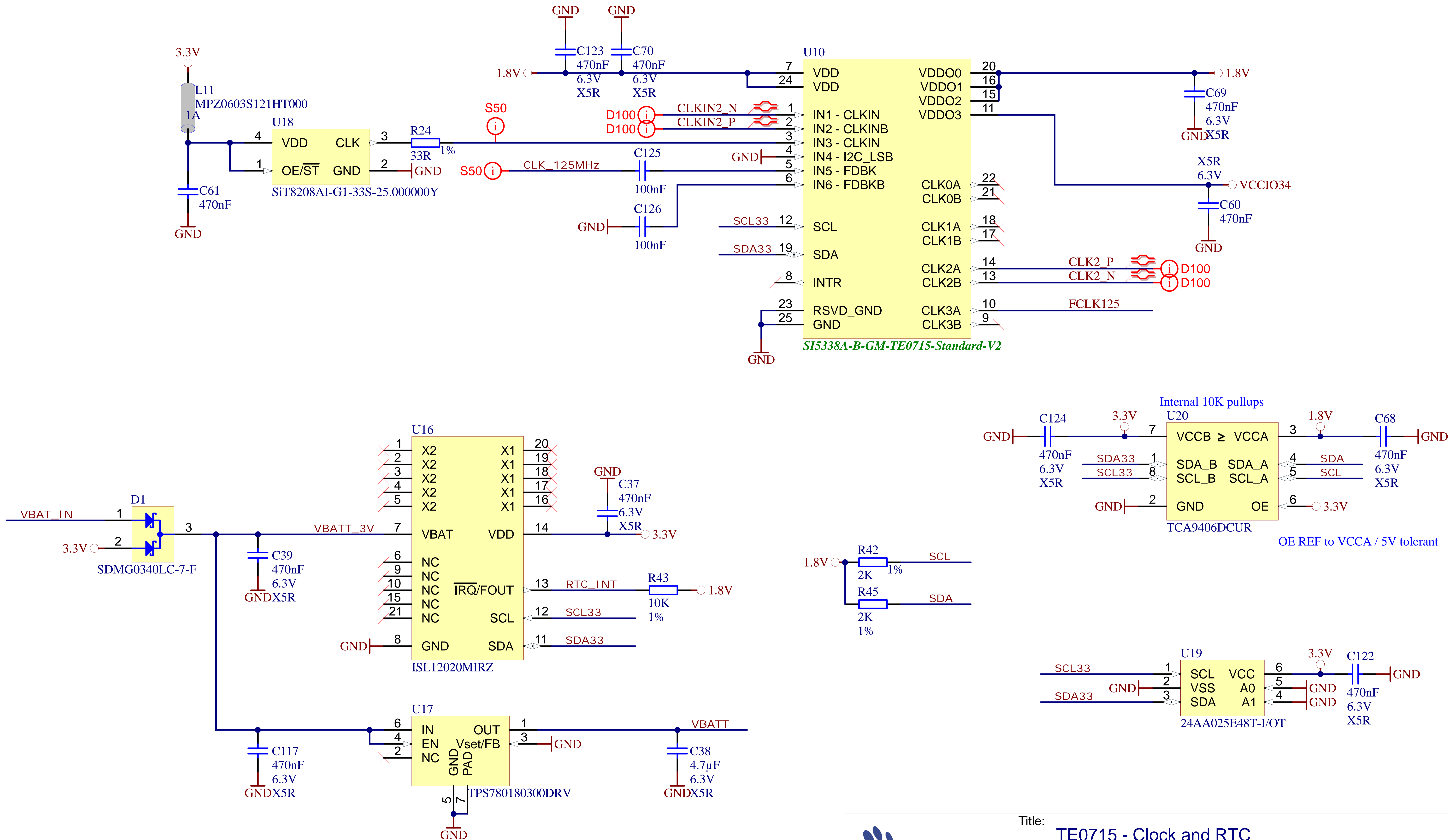

			Title: TE0715 - Clock and RTC	
			A4	Number: TE0715 21C33-A
Date: 04.05.2022		Copyright: Trenz Electronic GmbH		Page 15 of 20
Filename: Clock.SchDoc				

A

B

C

D

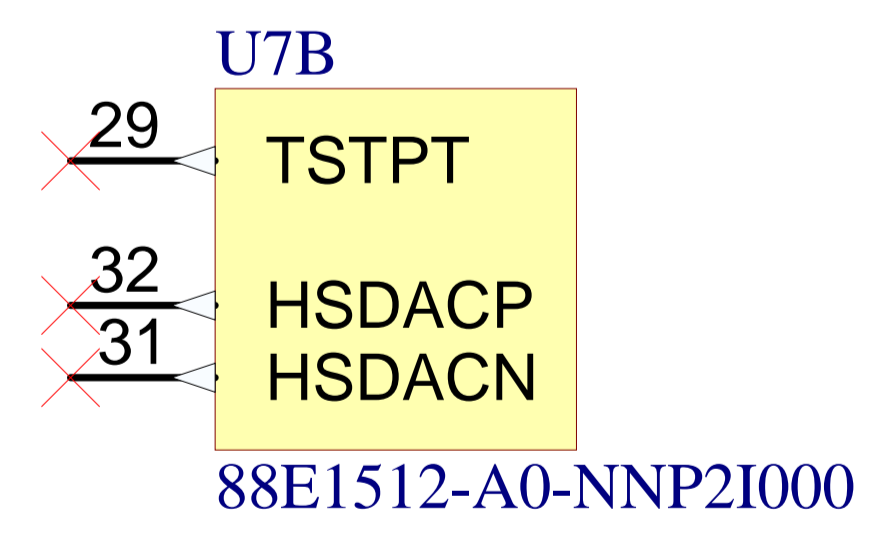
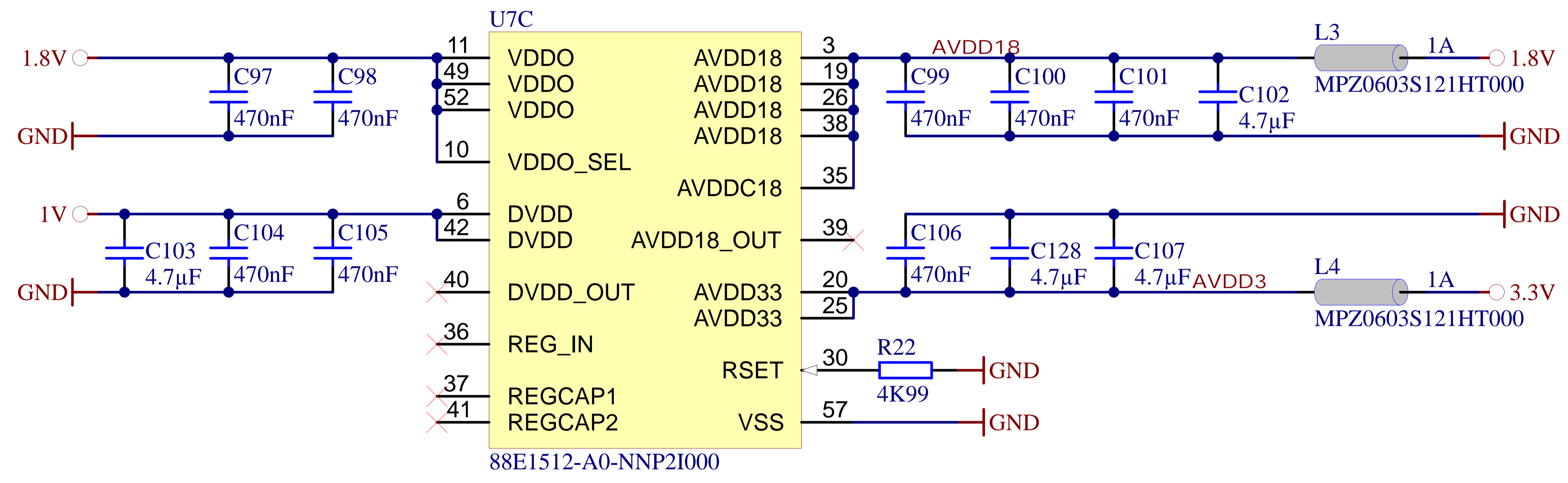
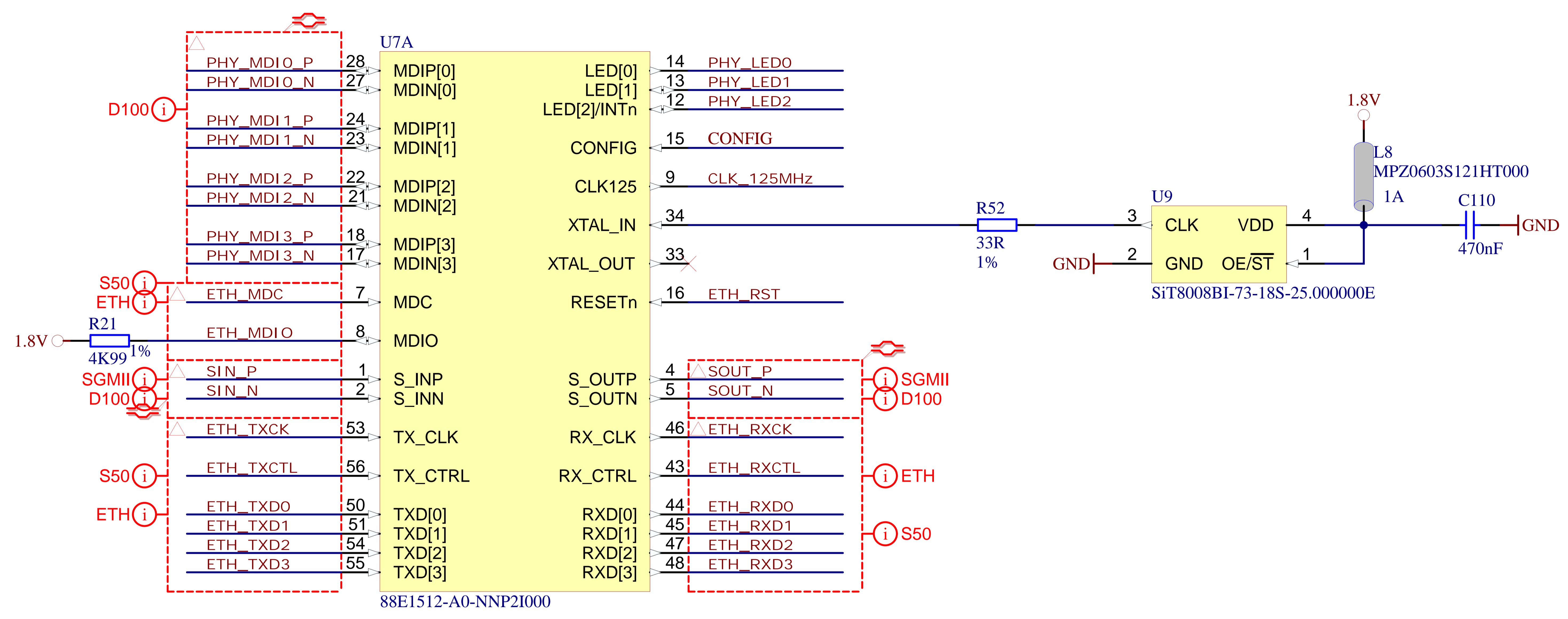

Title: TE0715 - ETH_PHY		
A4	Number: TE0715 21C33-A	Rev. 05
Date: 04.05.2022	Copyright: Trenz Electronic GmbH	Page 16 of 20
Filename: ETH-PHY.SchDoc		

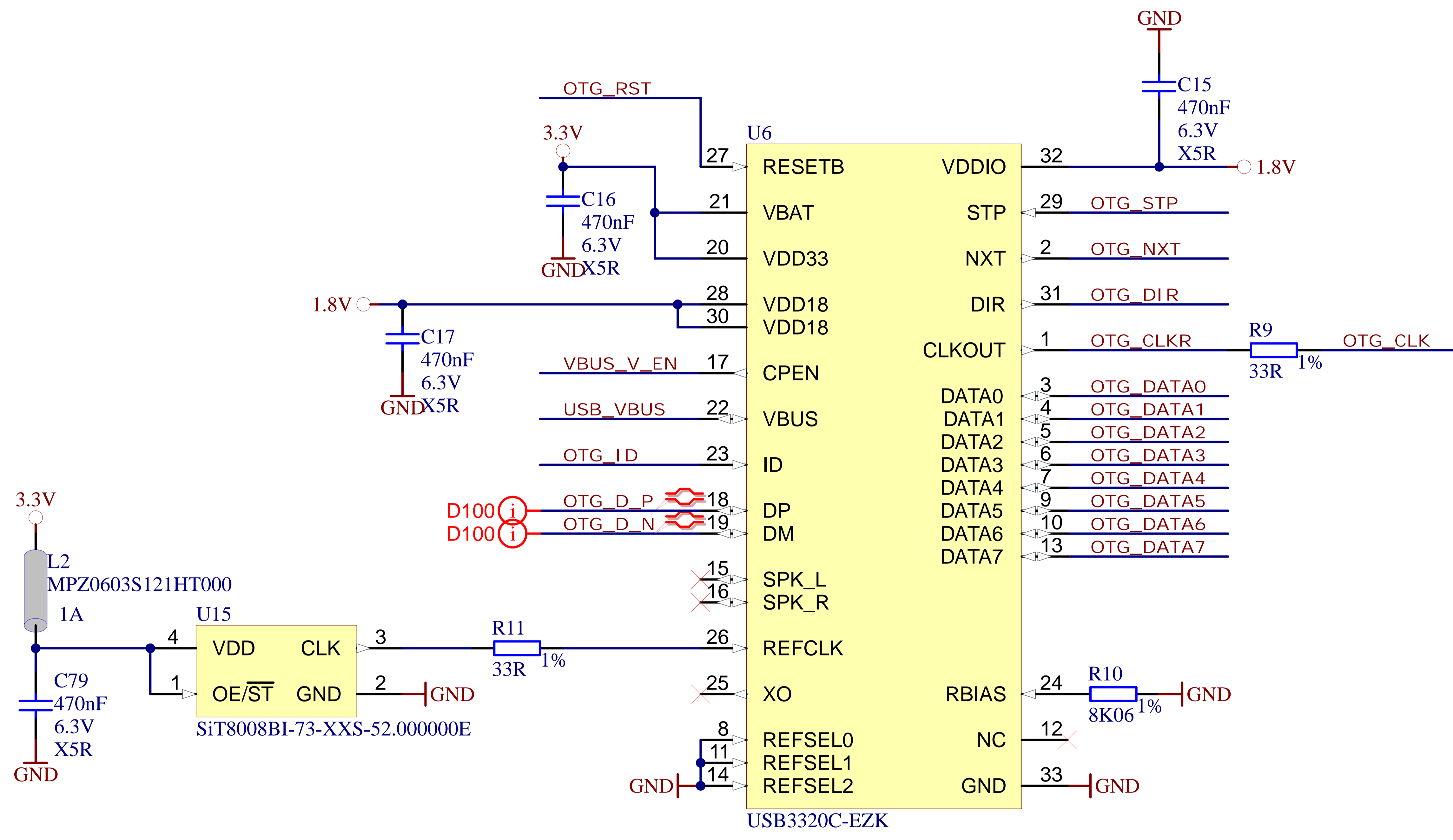

	Title: TE0715 - USB_PHY	
	A4	Number: TE0715 21C33-A
	Date: 04.05.2022	Rev. 05
	Copyright: Trenz Electronic GmbH	
Page 17 of 20		
Filename: USB-PHY.SchDoc		

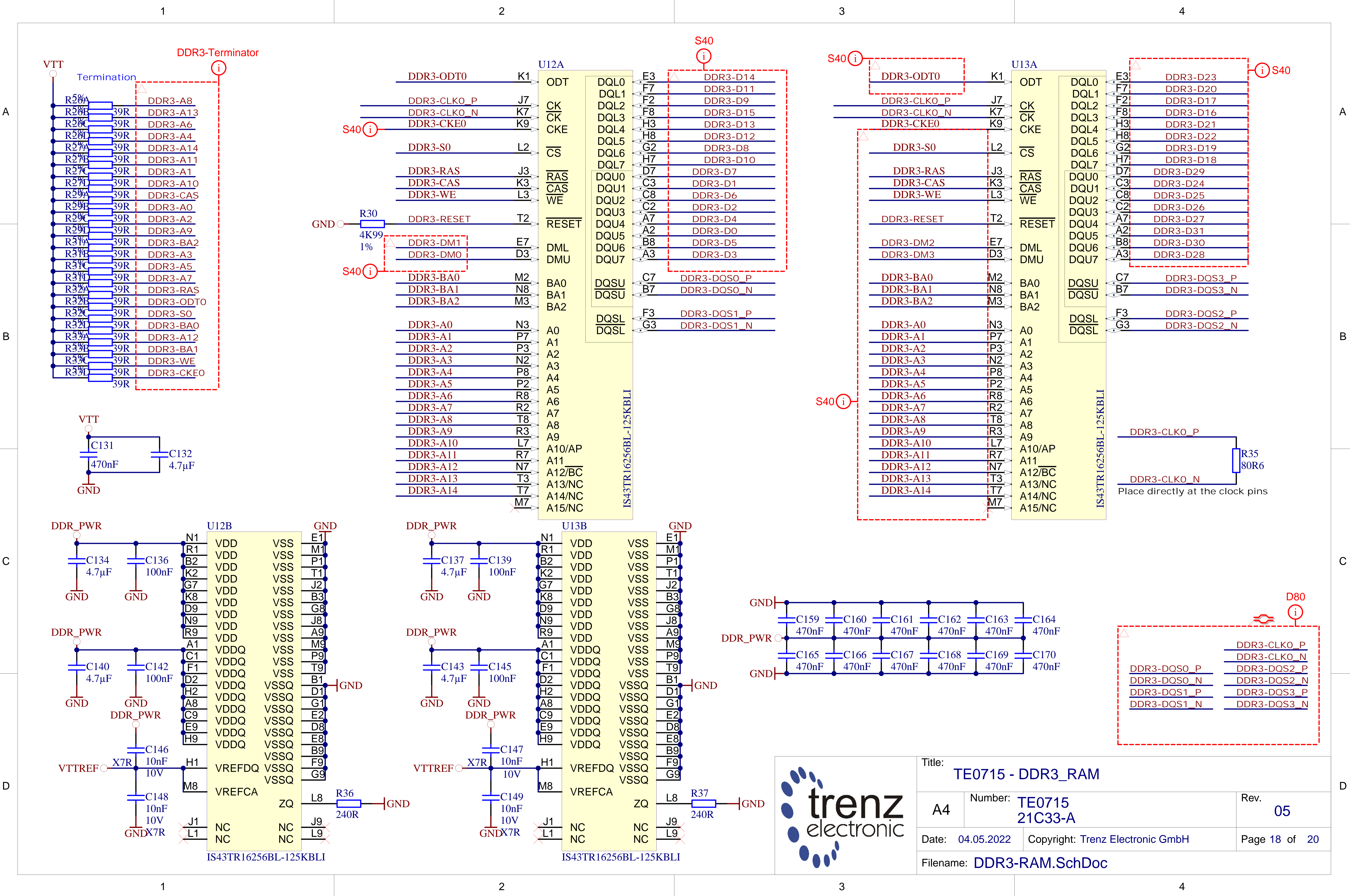

Title: TE0715 - DDR3_RAM		
A4	Number: TE0715 21C33-A	Rev. 05
Date: 04.05.2022	Copyright: Trenz Electronic GmbH	Page 18 of 20
Filename: DDR3-RAM.SchDoc		

- VIN ○ TP1 ● Testpoint 0.8mm
- DDR_PWR ○ TP2 ● Testpoint 0.8mm
- 1.8V ○ TP3 ● Testpoint 0.8mm
- 3.3V ○ TP4 ● Testpoint 0.8mm
- VTT ○ TP5 ● Testpoint 0.8mm
- VTTREF ○ TP6 ● Testpoint 0.8mm
- 3.3VIN ○ TP7 ● Testpoint 0.8mm
- 1.2V_MGT ○ TP8 ● Testpoint 0.8mm
- 1V ○ TP9 ● Testpoint 0.8mm
- GND | TP10 ● Testpoint 0.8mm
- GND | TP11 ● Testpoint 0.8mm
- GND | TP12 ● Testpoint 0.8mm

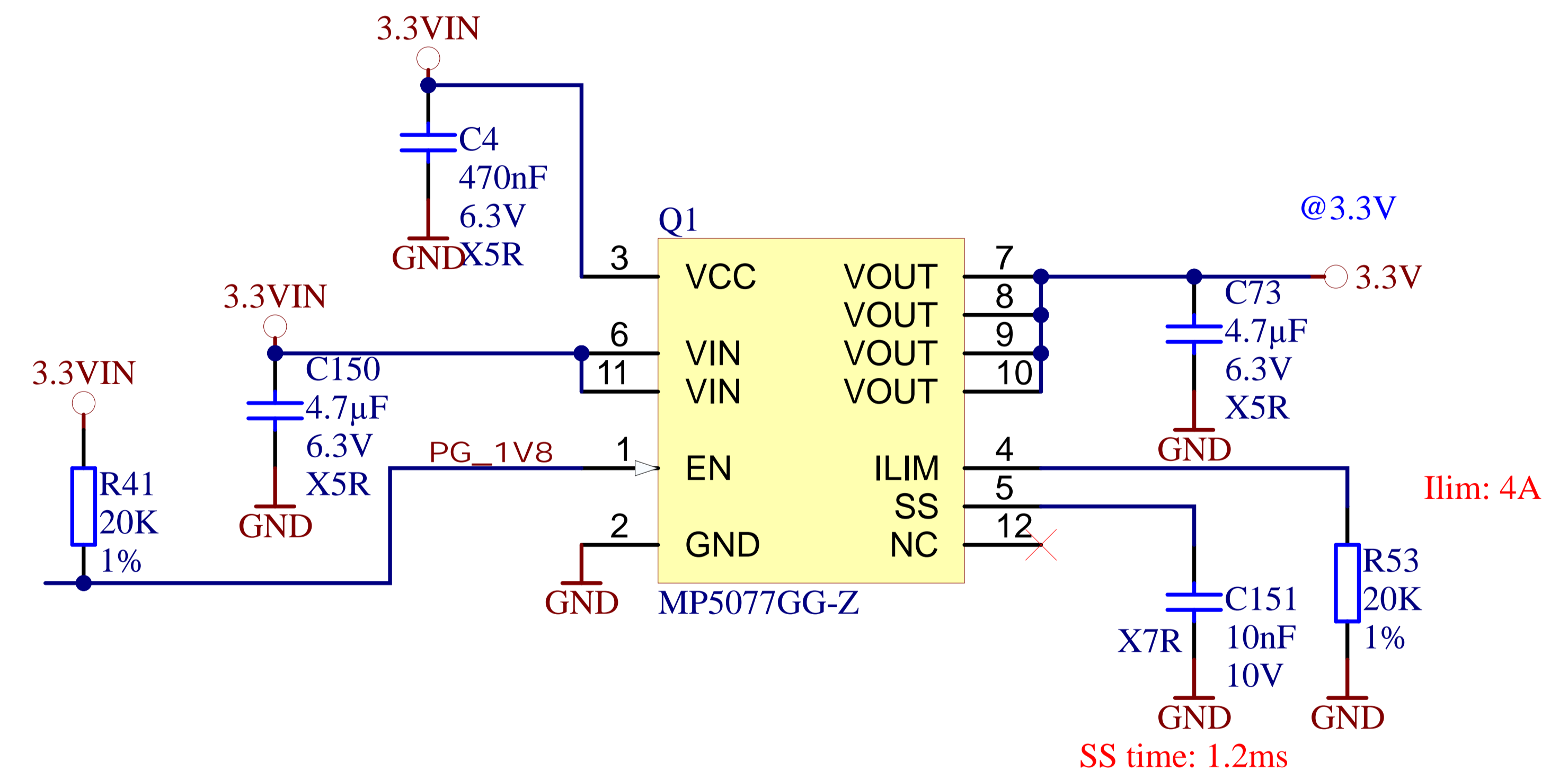
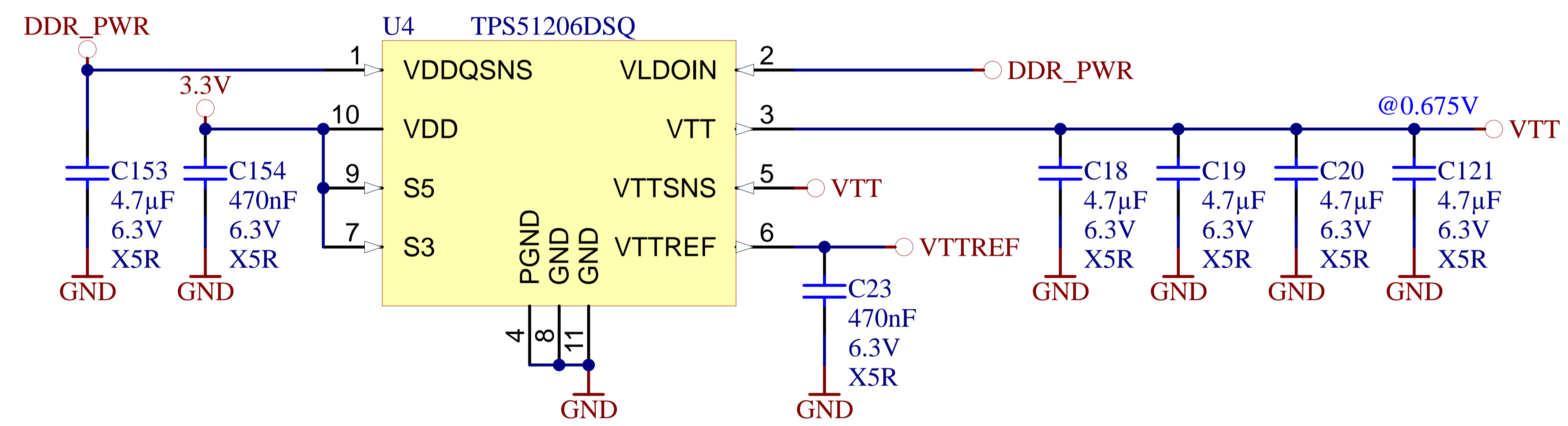
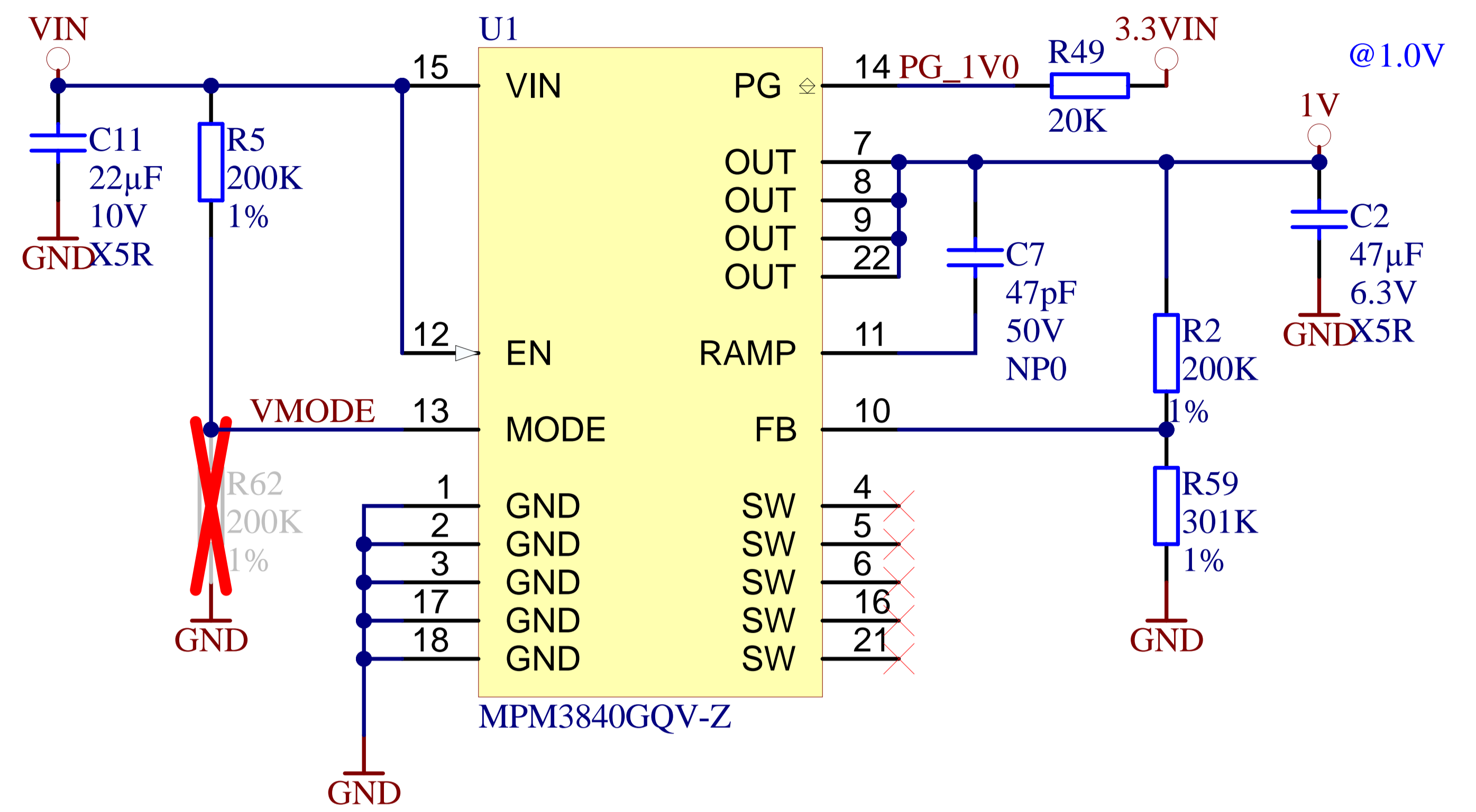

	Title: TE0715 - Power	
	A4	Number: TE0715 21C33-A
	Date: 26.10.2022	Copyright: Trenz Electronic GmbH
	Rev. 05	
Filename: POWER.SchDoc		Page 19 of 20

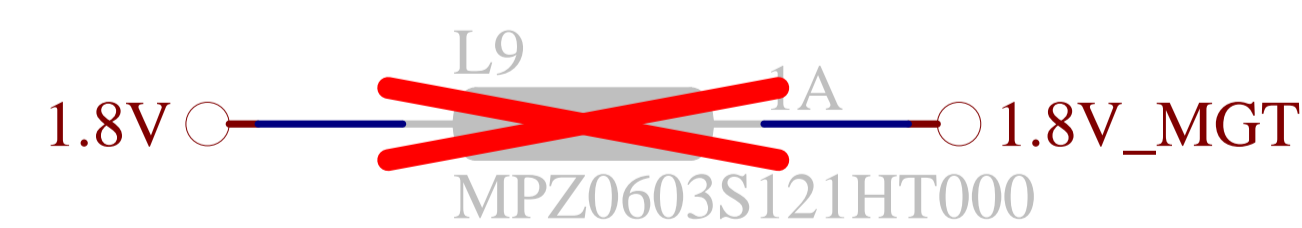
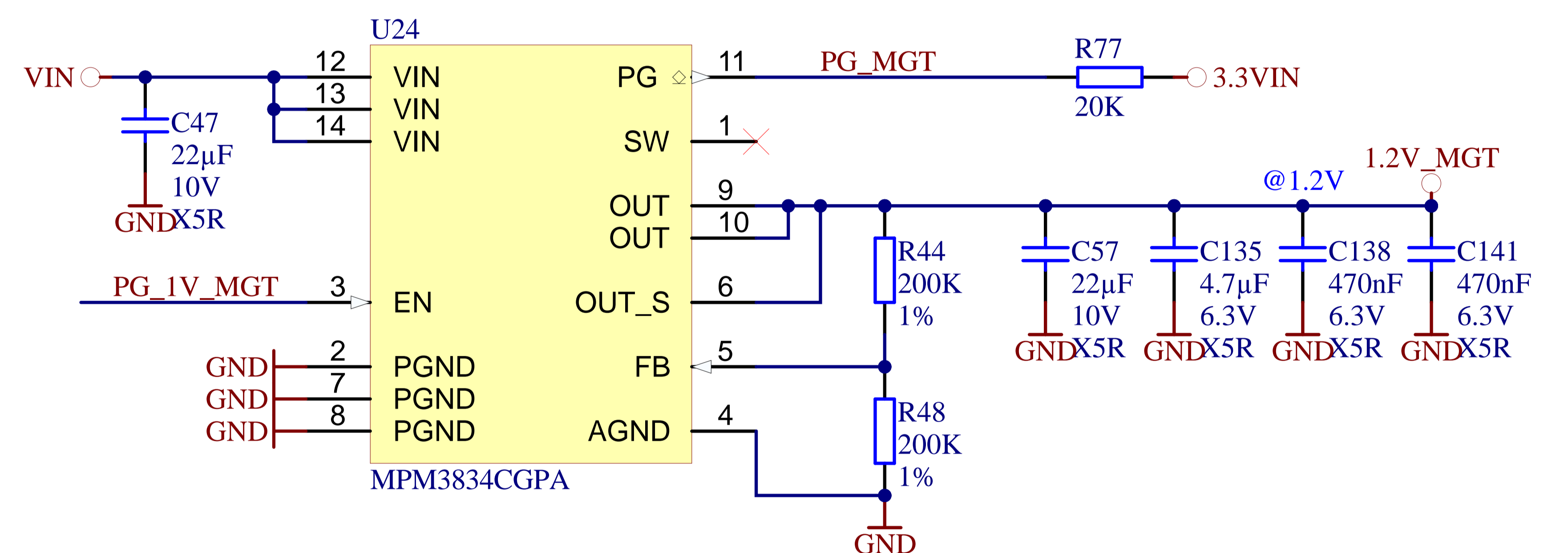
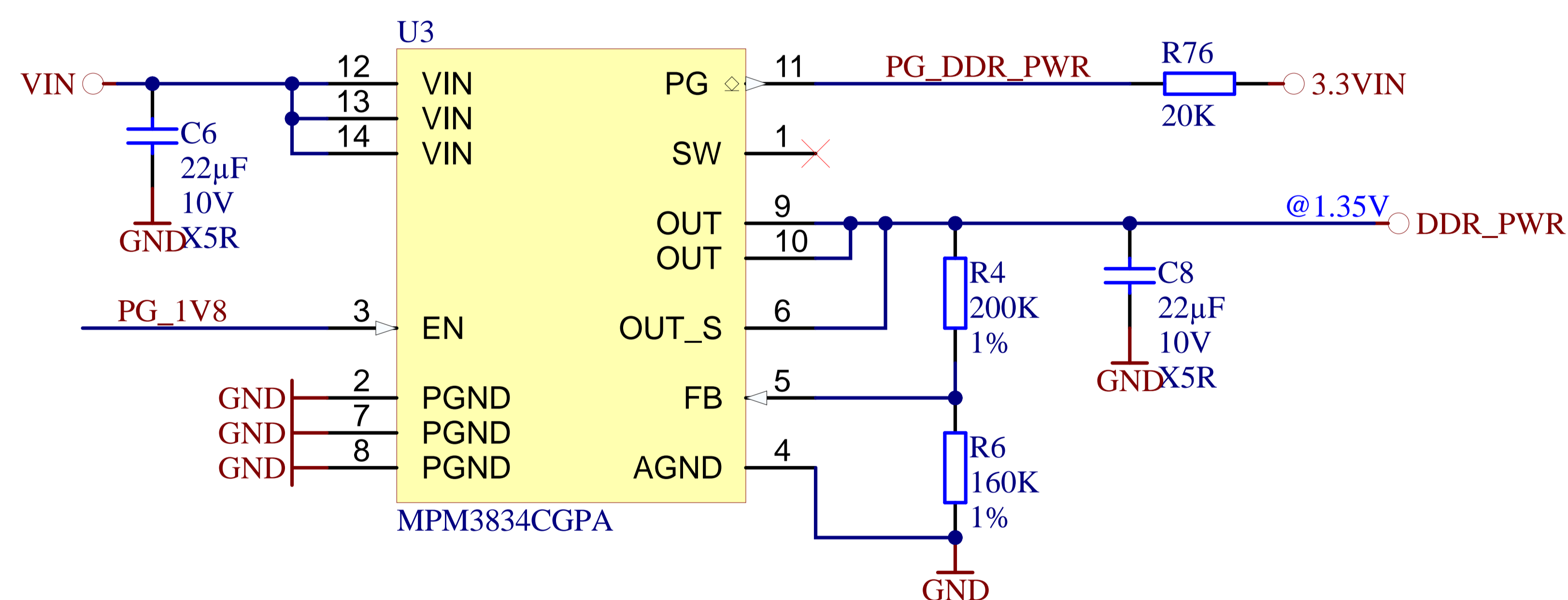
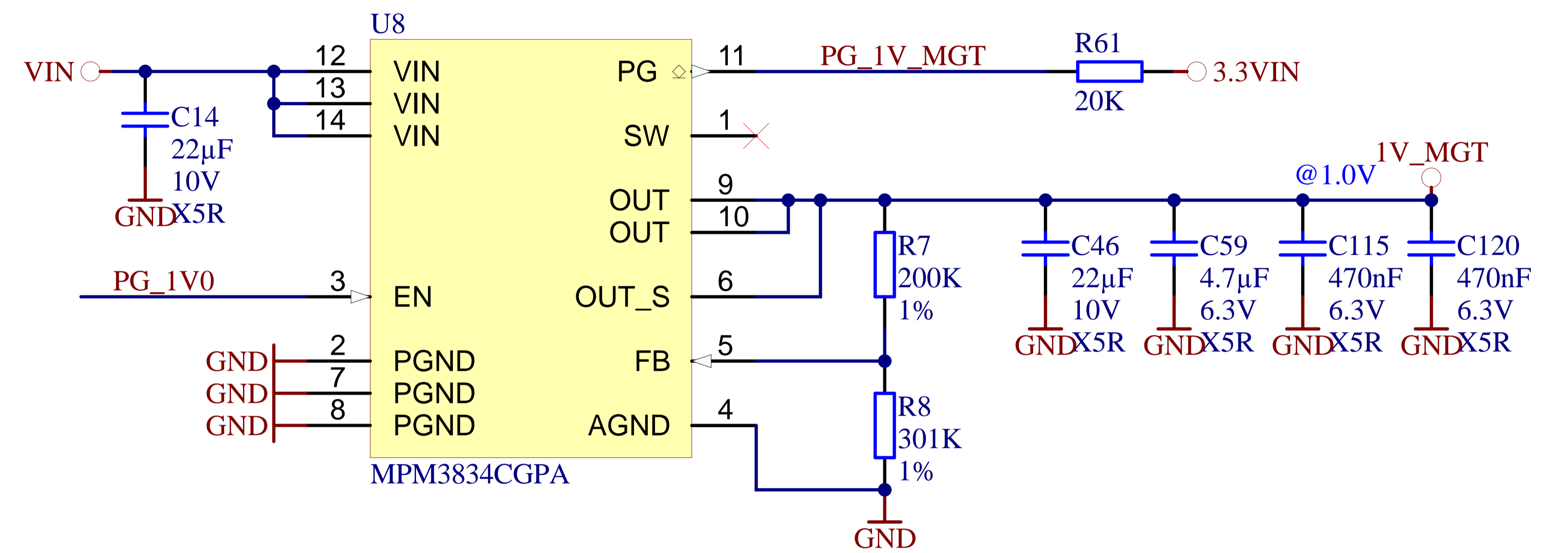
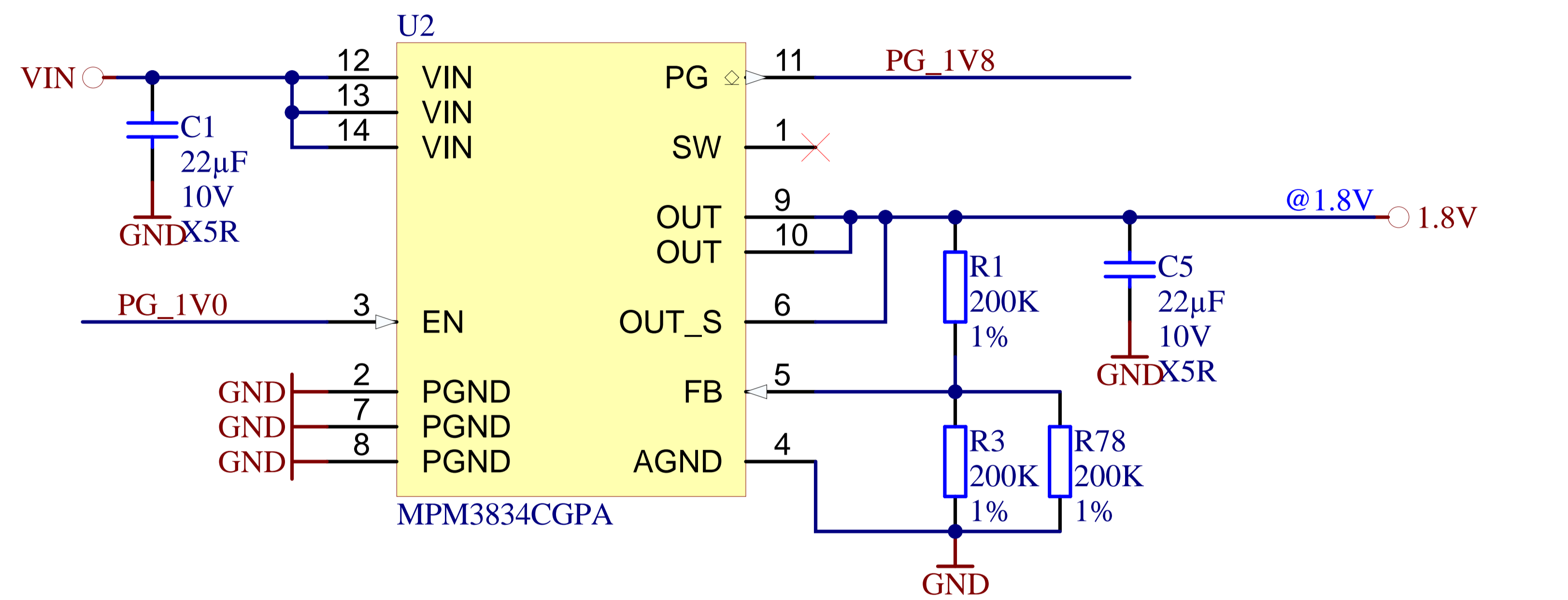

Title: TE0715 - Power		
A4	Number: TE0715 21C33-A	Rev. 05
Date: 04.05.2022	Copyright: Trenz Electronic GmbH	Page 20 of 20
Filename: POWER_2.SchDoc		